

2024

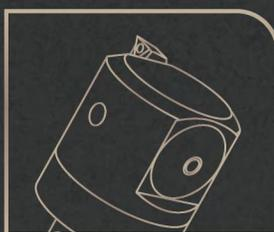

**镗刀** BORING  
TOOLS

# 镗刀目录 Boring Tools Contents

## N 命名方式 Naming And Coding Rules

005

## R 粗镗刀 BRA 系列 Rough-Boring BRA Series

006-017

BRA-CC 系列	BRA-CC Series	008
BRA-CC 系列滑块式刀夹	BRA-CC Series Sliding Cartridge	009
BRA-TC 系列	BRA-TC Series	011
BRA-TC 系列滑块式刀夹	BRA-TC Series Sliding Cartridge	012
BRA-SC 系列	BRA-SC Series	014
BRA-SC 系列滑块式刀夹	BRA-SC Series Sliding Cartridge	015
BRA 系列刀座	BRA Series Adaptor	017

## R 粗镗刀 BRB 系列 Rough-Boring BRB Series

018-045

BRB-CC-S 系列	BRB-CC-S Serie	020
BRB-CC-S 系列刀夹	BRB-CC-S Series Cartridge	022
BRB-TC-S 系列	BRB-TC-S Series	023
BRB-TC-S 系列刀夹	BRB-TC-S Series Cartridge	025
BRB-SC-S 系列	BRB-SC-S Series	026
BRB-SC-S 系列刀夹	BRB-SC-S Series Cartridge	028
BRB-CN-D 系列	BRB-CN-D Series	029
BRB-CN-D 系列刀夹	BRB-CN-D Series Cartridge	032
BRB-SN-D 系列	BRB-SN-D Series	033
BRB-SN-D 系列刀夹	BRB-SN-D Series Cartridge	035
BRB-CN-P 系列	BRB-CN-P Series	036
BRB-CN-P 系列刀夹	BRB-CN-P Series Cartridge	039
BRB-SN-P 系列	BRB-SN-P Series	040
BRB-SN-P 系列刀夹	BRB-SN-P Series Cartridge	042
BRB 系列桥架式刀座	BRB Series Bridge Adaptor	043
BRB 系列滑块	BRB Series Slide	045

## F 精镗刀 BFI 系列 Fine-Boring BFI Series

046-063

BFI 系列	BFI Series	048
BFI 系列刀座	BFI Series Adaptor	055
BFI 系列刀夹	BFI Series Cartridge	056
BFI 系列加长垫圈组件	BFI Series Extended Washer Assembly	058
BFI-Min 系列	BFI-Min Series	059
BFI-Min 系列刀座	BFI-Min series Adaptor	060
BFI-Min 系列刀夹	BFI-Min series Cartridge	061
BFI-Min 系列镗刀杆	BFI-Min series Boring Bar	062

## F 精镗刀 BFB 系列 Fine-Boring BFB Series

064-073

BFB 系列	BFB Series	066
BFB 系列滑块	BFB Series Slide	069
BFB 系列配重滑块	BFB Series Slide(CW)	070
BFB 系列精镗刀座	BFB Series Adaptor	071
BFB 系列配重块	BFB Series Counter-Weight	072

## F 精镗刀 BFH 系列 Fine-Boring BFH Series

074-083

BFH 系列	BFH Series	076
夹套	Jacket	077
侧固式连接杆	Side-clamped Connection Rod	078
镗刀杆	Boring Bar	079
镗刀头	Boring Head	081

## D 数显精镗刀 BFD-I 系列 Digital Display Fine-Boring BFD-I Series

084-097

BFD-I 系列	BFD-I Series	086
BFD-I 系列刀座	BFD-I Series Adaptor	093
BFD-I 系列刀夹	BFD-I Series Cartridge	094
BFD-I 系列加长垫圈组件	BFD-I Series Extended Washer Assembly	096

## 镗刀目录 Boring Tools Contents

### D 数显精镗刀 BFD-B 系列 Digital Display Fine-Boring BFD-B Series

098-107

BFD-B 系列	BFD-B Series	100
BFD-B 系列滑块	BFD-B Series Slide	104
BFD-B 系列配重滑块	BFD-B Series Slide(CW)	105
BFD-B 系列精镗刀座	BFD-B Series Adaptor	106
BFD-B 系列配重块	BFD-B Series Counter-Weight	107

### D 数显精镗刀 BFD-H 插杆系列 Digital Display Fine-Boring BFD-H Series

108-117

BFD-H 插杆系列	BFD-H Series	110
数字化镗刀显示器	Display	111
夹套	Jacket	112
侧固式连接杆	Side-clamped Connection Rod	113
镗刀杆	Boring Bar	114
镗刀头	Boring Head	116

### F 精镗刀 BFG 系列 Fine-Boring BFG Series

118-123

BFG-TC 系列	BFG-TC Series	120
BFG 系列刀夹	BFG Series Cartridge	122

### D 镗刀转接柄 Boring Tool Adaptor & Holderr

124-143

命名方式	Naming And Coding Rules	126
CK 基础柄 PSC 系列	CK Connection with PSC Adaptor	127
CK 基础柄 HSK 系列	CK Connection with HSK Adaptor	129
CK 基础柄 BT 系列	CK Connection with BT Adaptor	131
CK 基础柄 SK 系列	CK Connection with SK Adaptor	133
CK 接口等径延长杆	Extension with CK Adaptor	135
CK 接口缩径杆	Reduction with CK Adaptor	136
芯轴基础柄 BT 系列	Arbor Connection with BT Adaptor	137
芯轴基础柄 HSK 系列	Arbor Connection with HSK Adaptor	139
芯轴基础柄 SK 系列	Arbor Connection with SK Adaptor	140
转接柄	Transfer Adaptor	141
刀具扩展组装示意图	Extended Tools Assembly View	142

## 命名方式 Naming And Coding Rules



01 镗刀类型 Boring Tools Type	
BRA	粗镗刀 A 系列 A Series Rough Boring Tools
BRB	粗镗刀 B 系列 B Series Rough Boring Tools
BFI	精镗刀 I 系列 I Series Fine Boring Tools
BFB	精镗刀 B 系列 B Series Fine Boring Tools
BFH	精镗刀 H 系列 H Series Fine Boring Tools
BFD	精镗刀 D 系列 D Series Fine Boring Tools

02 直径范围 Processing range					
BRA	BRB	BFI	BFB	BFH	BFD
025035	160215	020025	160230	10	025032
035045	215270	025032	215285	12	032042
045055	270350	032042	270365	16	042055
055070	350430	042055	350445		055070
070085	430510	055070	430525		070100
085105		070100			100160
105130		100160			
130160					

03 刀片 Insert			
CC06	CN12	SC09	TC06
CC09	CN16	SC12	TC09
CC12	CN19	SN12	TC11
TP08	TB06	SN15	TC16
TP09			TC22

04 锁紧方式 Clamping	
D	压板式 Platen
P	勾杆式 Hook
S	螺钉式 Screw

05 接口规格 Coupling Type	
CKB1	A22A
CKB2	A32A
CKB3	A40C
CKB4	A60C
CKB5	
CKB6	
CKB7	

06 EW 数显	
6	

- 注：镗刀头接口规格 CKB 与镗刀接柄 CK 属于同一接口规格，配合使用
- Note: Boring tool head with CKB interface can match boring tool connection CK series. Their interface specifications are consistent

# 粗镗刀BRA系列

ROUGH-BORING BRA SERIES

## 01

适用于 $\Phi 25$ - $\Phi 160$ mm的孔径加工  
Apply to  $\Phi 25$ - $\Phi 160$ mm aperture machining

## 03

合金钢底座配合特殊表面处理提高了刀体的刚性及耐磨性

Alloy steel tool body with special surface treatment improves the rigidity and wear resistance

## 02

加工孔径公差 $\pm 0.05$

Machining aperture tolerance  $\pm 0.05$ mm

## 04

滑块式刀夹装载ISO刀片，市场通用性好

The sliding cartridge equipped with ISO inserts is with good market versatility



## BRA-CC 系列

BRA-CC series

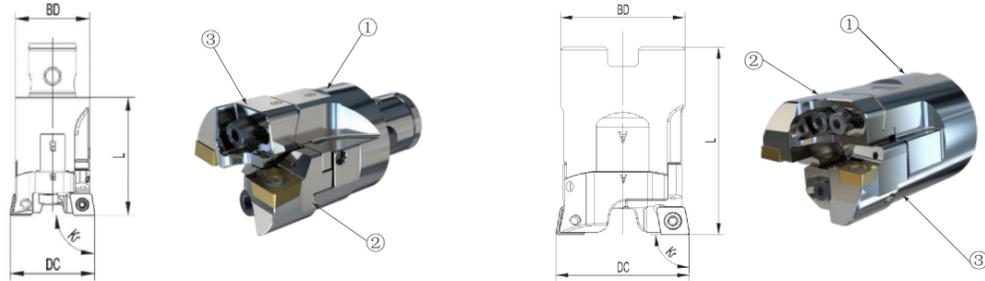

类型 1 | Type 1

类型 2 | Type 2

- 内冷却液供应
- CCMT CCGT CCGX CCET CCMW
- 刀片仅做示意

- Internal coolant supply
- CCMT CCGT CCGX CCET CCMW
- The insert is for illustration only

### 技术参数 | Technical parameters

单位 | Unit: mm

订货号 Ordering code	镗削范围   Boring Range(DC)			尺寸   Dimension				刀片 Insert	接口   Coupling	
	Min.	Max.	Adj.	L	BD	Kr	KG		Form	Type
BRA-025035-CC06-S-CKB2	25	35	5	35	22	90	0.10	CC.. 060204	CKB2	1
BRA-035045-CC09-S-CKB3	35	45	5	40	31	90	0.22	CC.. 09T308	CKB3	1
BRA-045055-CC09-S-A22A	45	55	5	65	42	90	0.47	CC.. 09T308	ARB-22A	2
BRA-055070-CC12-S-A22A	55	70	7.5	68	42	90	0.64	CC.. 120408	ARB-22A	2
BRA-070085-CC12-S-A32A	70	85	7.5	78	63	90	1.25	CC.. 120408	ARB-32A	2
BRA-085105-CC12-S-A32A	85	105	10	78	63	90	1.60	CC.. 120408	ARB-32A	2
BRA-105130-CC12-S-A32A	105	130	12.5	78	63	90	2.13	CC.. 120408	ARB-32A	2
BRA-130160-CC12-S-A32A	130	160	15	78	63	90	2.67	CC.. 120408	ARB-32A	2

### 备件 | Accessory

产品型号 Product ID	①	②	③				
	刀座 Adapto	滑块式刀夹 A Sliding Cartridge A	滑块式刀夹 B Sliding Cartridge B	刀片螺钉扳手 Key(Insert)	刀垫螺钉扳手 Key(Shim)	锁紧螺钉扳手 Key(Screw)	锁紧螺钉扳手 Key(Adj.)
BRA-025035-CC06-S-CKB2	BPRA-CKB2-025024	BPRA-SL-CC06-S-OA	BPRA-SL-CC06-S-OB	242.070.35	-	241.025.56	241.013.40
BRA-035045-CC09-S-CKB3	BPRA-CKB3-035026	BPRA-SL-CC09-S-PA	BPRA-SL-CC09-S-PB	248.150.10	-	241.030.63	246.015.60
BRA-045055-CC09-S-A22A	BPRA-A22A-045046	BPRA-SL-CC09-S-QA	BPRA-SL-CC09-S-QB	248.150.10	-	241.030.63	246.015.60
BRA-055070-CC12-S-A22A	BPRA-A22A-055046	BPRA-SL-CC12-S-RA	BPRA-SL-CC12-S-RB	248.150.10	-	241.040.70	246.020.60
BRA-070085-CC12-S-A32A	BPRA-A32A-070056	BPRA-SL-CC12-S-SA	BPRA-SL-CC12-S-SB	248.150.10	241.040.70	241.050.80	246.025.60
BRA-085105-CC12-S-A32A	BPRA-A32A-085056	BPRA-SL-CC12-S-TA	BPRA-SL-CC12-S-TB	248.150.10	241.040.70	241.060.90	246.030.60
BRA-105130-CC12-S-A32A	BPRA-A32A-105056	BPRA-SL-CC12-S-UA	BPRA-SL-CC12-S-UB	248.150.10	241.040.70	241.060.90	246.030.60
BRA-130160-CC12-S-A32A	BPRA-A32A-130056	BPRA-SL-CC12-S-VA	BPRA-SL-CC12-S-VB	248.150.10	241.040.70	241.060.90	246.030.60

- 可单独订购备件，按需询价
- 关于 BRA 系列刀座请参阅 P17

- The spare parts can be ordered separately. Please inquire on demand
- Please refer to P17 for BRA series Adaptor

## BRA-CC 系列滑块式刀夹

BRA-CC Series Sliding Cartridge

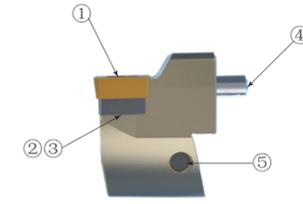

- CCMT CCGT CCGX CCET CCMW
- 刀片仅做示意

- CCMT CCGT CCGX CCET CCMW
- The insert is for illustration only

### 技术参数 | Technical parameters

单位 | Unit: mm

订货号 Ordering code	直径范围 Fitting Range	刀片 Insert	夹紧方式 Clamping
BPRA-SL-CC06-S-OA	25-35	CC.. 060204	S
BPRA-SL-CC06-S-OB	25-35	CC.. 060204	S
BPRA-SL-CC09-S-PA	35-45	CC.. 09T308	S
BPRA-SL-CC09-S-PB	35-45	CC.. 09T308	S
BPRA-SL-CC09-S-QA	45-55	CC.. 09T308	S
BPRA-SL-CC09-S-QB	45-55	CC.. 09T308	S
BPRA-SL-CC12-S-RA	55-70	CC.. 120408	S
BPRA-SL-CC12-S-RB	55-70	CC.. 120408	S
BPRA-SL-CC12-S-SA	70-85	CC.. 120408	S
BPRA-SL-CC12-S-SB	70-85	CC.. 120408	S
BPRA-SL-CC12-S-TA	85-105	CC.. 120408	S
BPRA-SL-CC12-S-TB	85-105	CC.. 120408	S
BPRA-SL-CC12-S-UA	105-130	CC.. 120408	S
BPRA-SL-CC12-S-UB	105-130	CC.. 120408	S
BPRA-SL-CC12-S-VA	130-160	CC.. 120408	S
BPRA-SL-CC12-S-VB	130-160	CC.. 120408	S

转下页 see next page →

## BRA-CC 系列滑块式刀夹

BRA-CC Series Sliding Cartridge

产品型号 Product ID	备件   Accessory					单独订购   Purchase Separately		
	① 刀片螺钉 Screw(Insert)	② 刀垫 Shim	③ 刀片螺钉 Screw(Insert)	④ 弹性销 Cotter	⑤ 调整螺钉 Screw(Adj.)	刀片螺钉扳手 Key(Insert)	刀垫螺钉扳手 Key(Shim)	调整螺钉扳手 Key(Adj.)
BPRA-SL-CC06-S-OA	SFS-2565	-	-	179.015.08	-	242.070.35	-	-
BPRA-SL-CC06-S-OB	SFS-2565	-	-	179.015.08	-	242.070.35	-	-
BPRA-SL-CC09-S-PA	SFS 3581	-	-	179.025.08	-	248.150.10	-	-
BPRA-SL-CC09-S-PB	SFS 3581	-	-	179.025.08	-	248.150.10	-	-
BPRA-SL-CC09-S-QA	SFS 3581	-	-	-	253.030.10	248.150.10	-	246.015.60
BPRA-SL-CC09-S-QB	SFS 3581	-	-	-	253.030.10	248.150.10	-	246.015.60
BPRA-SL-CC12-S-RA	ILD 4011-A	-	-	-	253.040.12	248.150.10	-	246.020.60
BPRA-SL-CC12-S-RB	ILD 4011-A	-	-	-	253.040.12	248.150.10	-	246.020.60
BPRA-SL-CC12-S-SA	ILD 4014	322.232.02	512.090.03	-	253.050.12	248.150.10	241.040.70	246.025.60
BPRA-SL-CC12-S-SB	ILD 4014	322.232.02	512.090.03	-	253.050.12	248.150.10	241.040.70	246.025.60
BPRA-SL-CC12-S-TA	ILD 4014	322.232.02	512.090.03	-	253.060.16	248.150.10	241.040.70	246.030.60
BPRA-SL-CC12-S-TB	ILD 4014	322.232.02	512.090.03	-	253.060.16	248.150.10	241.040.70	246.030.60
BPRA-SL-CC12-S-UA	ILD 4014	322.232.02	512.090.03	179.060.16	-	248.150.10	241.040.70	-
BPRA-SL-CC12-S-UB	ILD 4014	322.232.02	512.090.03	179.060.16	-	248.150.10	241.040.70	-
BPRA-SL-CC12-S-VA	ILD 4014	322.232.02	512.090.03	179.060.16	-	248.150.10	241.040.70	-
BPRA-SL-CC12-S-VB	ILD 4014	322.232.02	512.090.03	179.060.16	-	248.150.10	241.040.70	-

• 可单独订购备件，按需询价

• The spare parts can be ordered separately. Please inquire on demand

## BRA-TC 系列

BRA-TC series

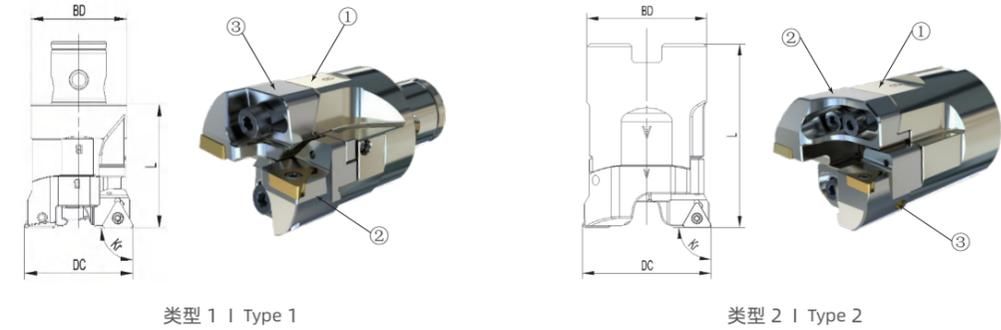

- 内冷却液供应
- TCMT TCMX TCGT TCGX TCEX TCMW
- 刀片仅做示意

- Internal coolant supply
- TCMT TCMX TCGT TCGX TCEX TCMW
- The insert is for illustration only

### 技术参数 | Technical parameters

单位 | Unit: mm

订货号 Ordering code	镗削范围   Boring Range(DC)			尺寸   Dimension				刀片 Insert	接口   Coupling	
	Min.	Max.	Adj.	L	BD	Kr	KG		Form	Type
BRA-035045-TC11-S-CKB3	35	45	5	40	31	90	0.22	TC.. 110308	CKB3	1
BRA-045055-TC11-S-A22A	45	55	5	65	42	90	0.47	TC.. 110308	A22A	2
BRA-055070-TC16-S-A22A	55	70	7.5	68	42	90	0.64	TC.. 16T308	A22A	2
BRA-070085-TC16-S-A32A	70	85	7.5	78	63	90	1.25	TC.. 16T308	A32A	2
BRA-085105-TC16-S-A32A	85	105	10	78	63	90	1.60	TC.. 16T308	A32A	2
BRA-105130-TC16-S-A32A	105	130	12.5	78	63	90	2.13	TC.. 16T308	A32A	2
BRA-130160-TC16-S-A32A	130	160	15	78	63	90	2.67	TC.. 16T308	A32A	2

### 备件 | Accessory

产品型号 Product ID	①	②	③	刀片螺钉扳手 Key(Insert)	刀垫螺钉扳手 Key(Shim)	锁紧螺钉扳手 Key(Screw)	调整螺钉扳手 Key(Adj.)
	刀座 Adapto	滑块式刀夹 A Sliding Cartridge A	滑块式刀夹 B Sliding Cartridge B				
BRA-035045-TC11-S-CKB3	BPRA-CKB3-035026	BPRA-SL-TC11-S-PA	BPRA-SL-TC11-S-PB	242.070.35	-	241.030.63	246.015.60
BRA-045055-TC11-S-A22A	BPRA-A22A-045046	BPRA-SL-TC11-S-QA	BPRA-SL-TC11-S-QB	242.070.35	-	241.030.63	246.015.60
BRA-055070-TC16-S-A22A	BPRA-A22A-055046	BPRA-SL-TC16-S-RA	BPRA-SL-TC16-S-RB	248.150.10	-	241.040.70	246.020.60
BRA-070085-TC16-S-A32A	BPRA-A32A-070056	BPRA-SL-TC16-S-SA	BPRA-SL-TC16-S-SB	248.150.10	241.035.65	241.050.80	246.025.60
BRA-085105-TC16-S-A32A	BPRA-A32A-085056	BPRA-SL-TC16-S-TA	BPRA-SL-TC16-S-TB	248.150.10	241.035.65	241.060.90	246.030.60
BRA-105130-TC16-S-A32A	BPRA-A32A-105056	BPRA-SL-TC16-S-UA	BPRA-SL-TC16-S-UB	248.150.10	241.035.65	241.060.90	246.030.60
BRA-130160-TC16-S-A32A	BPRA-A32A-130056	BPRA-SL-TC16-S-VA	BPRA-SL-TC16-S-VB	248.150.10	241.035.65	241.060.90	246.030.60

- 可单独订购备件，按需询价
- 关于 BRA 系列刀座请参阅 P17

- The spare parts can be ordered separately. Please inquire on demand
- Please refer to P17 for BRA series Adaptor

## BRA-TC 系列滑块式刀夹

BRA-TC Series Sliding Cartridge

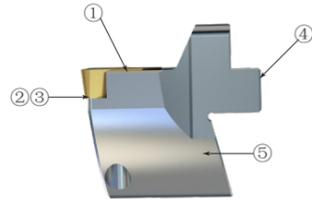
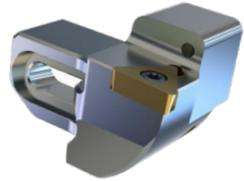

- TCMT TCMX TCGT TCGX TCEX TCMW
- 刀片仅做示意

- TCMT TCMX TCGT TCGX TCEX TCMW
- The insert is for illustration only

### 技术参数 | Technical parameters

单位 | Unit: mm

订货号 Ordering code	直径范围 Fitting Range	刀片 Insert	夹紧方式 Clamping
BPRA-SL-TC11-S-PA	35-45	TC.. 110308	S
BPRA-SL-TC11-S-PB	35-45	TC.. 110308	S
BPRA-SL-TC11-S-QA	45-55	TC.. 110308	S
BPRA-SL-TC11-S-QB	45-55	TC.. 110308	S
BPRA-SL-TC16-S-RA	55-70	TC.. 16T308	S
BPRA-SL-TC16-S-RB	55-70	TC.. 16T308	S
BPRA-SL-TC16-S-SA	70-85	TC.. 16T308	S
BPRA-SL-TC16-S-SB	70-85	TC.. 16T308	S
BPRA-SL-TC16-S-TA	85-105	TC.. 16T308	S
BPRA-SL-TC16-S-TB	85-105	TC.. 16T308	S
BPRA-SL-TC16-S-UA	105-130	TC.. 16T308	S
BPRA-SL-TC16-S-UB	105-130	TC.. 16T308	S
BPRA-SL-TC16-S-VA	130-160	TC.. 16T308	S
BPRA-SL-TC16-S-VB	130-160	TC.. 16T308	S

转下页 see next page →

## BRA-TC 系列滑块式刀夹

BRA-TC Series Sliding Cartridge

产品型号 Product ID	备件   Accessory					单独订购   Purchase Separately		
	① 刀片螺钉 Screw(Insert)	② 刀垫 Shim	③ 刀片螺钉 Screw(Insert)	④ 弹性销 Cotter	⑤ 调整螺钉 Screw(Adj.)	刀片螺钉扳手 Key(Insert)	刀垫螺钉扳手 Key(Shim)	调整螺钉扳手 Key(Adj.)
BPRA-SL-TC11-S-PA	SFS-2565	-	-	1179.025.08	-	242.070.35	-	-
BPRA-SL-TC11-S-PB	SFS-2565	-	-	179.025.08	-	242.070.35	-	-
BPRA-SL-TC11-S-QA	SFS-2565	-	-	-	253.030.10	242.070.35	-	246.015.60
BPRA-SL-TC11-S-QB	SFS-2565	-	-	-	253.030.10	242.070.35	-	246.015.60
BPRA-SL-TC16-S-RA	ILD3510	-	-	-	253.040.12	248.150.10	-	246.020.60
BPRA-SL-TC16-S-RB	ILD3510	-	-	-	253.040.12	248.150.10	-	246.020.60
BPRA-SL-TC16-S-SA	SFS_3512	322.320.01	512.090.01	-	253.050.12	248.150.10	241.035.65	246.025.60
BPRA-SL-TC16-S-SB	SFS_3512	322.320.01	512.090.01	-	253.050.12	248.150.10	241.035.65	246.025.60
BPRA-SL-TC16-S-TA	SFS_3512	322.320.01	512.090.01	-	253.060.16	248.150.10	241.035.65	246.030.60
BPRA-SL-TC16-S-TB	SFS_3512	322.320.01	512.090.01	-	253.060.16	248.150.10	241.035.65	246.030.60
BPRA-SL-TC16-S-UA	SFS_3512	322.320.01	512.090.01	179.060.16	-	248.150.10	241.035.65	-
BPRA-SL-TC16-S-UB	SFS_3512	322.320.01	512.090.01	179.060.16	-	248.150.10	241.035.65	-
BPRA-SL-TC16-S-VA	SFS_3512	322.320.01	512.090.01	179.060.16	-	248.150.10	241.035.65	-
BPRA-SL-TC16-S-VB	SFS_3512	322.320.01	512.090.01	179.060.16	-	248.150.10	241.035.65	-

- 可单独订购备件，按需询价

- The spare parts can be ordered separately. Please inquire on demand

## BRA-SC 系列

BRA-SC series

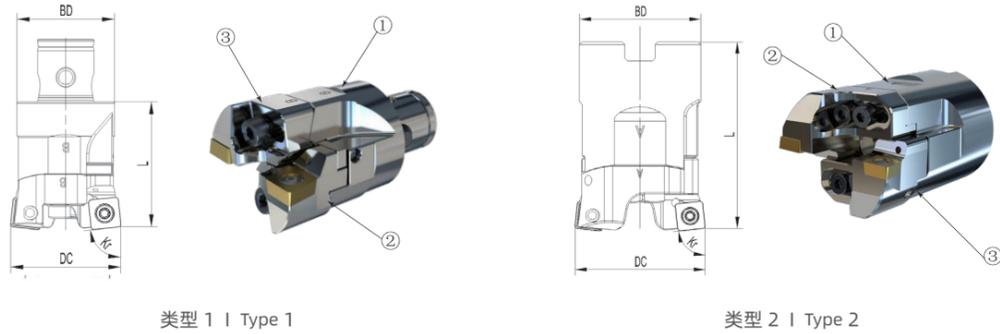

类型 1 | Type 1

类型 2 | Type 2

- 内冷却液供应
- SCMT SCGX SCMW
- 刀片仅做示意

- Internal coolant supply
- SCMT SCGX SCMW
- The insert is for illustration only

### 技术参数 | Technical parameters

单位 | Unit: mm

订货号 Ordering code	镗削范围   Boring Range(DC)			尺寸   Dimension				刀片 Insert	接口   Coupling	
	Min.	Max.	Adj.	L	BD	Kr	KG		Form	Type
BRA-035045-SC09-S-CKB3	35	45	5	40	31	84	0.22	SC.. 09T308	CKB3	1
BRA-045055-SC09-S-A22A	45	55	5	65	42	84	0.47	SC.. 09T308	A22A	2
BRA-055070-SC12-S-A22A	55	70	7.5	68	42	84	0.64	SC.. 120408	A22A	2
BRA-070085-SC12-S-A32A	70	85	7.5	78	63	84	1.25	SC.. 120408	A32A	2
BRA-085105-SC12-S-A32A	85	105	10	78	63	84	1.6	SC.. 120408	A32A	2
BRA-105130-SC12-S-A32A	105	130	12.5	78	63	84	2.13	SC.. 120408	A32A	2
BRA-130160-SC12-S-A32A	130	160	15	78	63	84	2.67	SC.. 120408	A32A	2

### 备件 | Accessory

产品型号 Product ID	①	②	③	刀片螺钉扳手 Key(Insert)	刀垫螺钉扳手 Key(Shim)	锁紧螺钉扳手 Key(Screw)	调整螺钉扳手 Key(Adj.)
	刀座 Adapto	滑块式刀夹 A Sliding Cartridge A	滑块式刀夹 B Sliding Cartridge B				
BRA-035045-SC09-S-CKB3	BPRA-CKB3-035026	BPRA-SL-SC09-S-PA	BPRA-SL-SC09-S-PB	248.150.10	-	241.030.63	246.015.60
BRA-045055-SC09-S-A22A	BPRA-A22A-045046	BPRA-SL-SC09-S-QA	BPRA-SL-SC09-S-QB	248.150.10	-	241.030.63	246.015.60
BRA-055070-SC12-S-A22A	BPRA-A22A-055046	BPRA-SL-SC12-S-RA	BPRA-SL-SC12-S-RB	248.150.10	-	241.040.70	246.020.60
BRA-070085-SC12-S-A32A	BPRA-A32A-070056	BPRA-SL-SC12-S-SA	BPRA-SL-SC12-S-SB	248.150.10	241.040.70	241.050.80	246.025.60
BRA-085105-SC12-S-A32A	BPRA-A32A-085056	BPRA-SL-SC12-S-TA	BPRA-SL-SC12-S-TB	248.150.10	241.040.70	241.060.90	246.030.60
BRA-105130-SC12-S-A32A	BPRA-A32A-105056	BPRA-SL-SC12-S-UA	BPRA-SL-SC12-S-UB	248.150.10	241.040.70	241.060.90	246.030.60
BRA-130160-SC12-S-A32A	BPRA-A32A-130056	BPRA-SL-SC12-S-VA	BPRA-SL-SC12-S-VB	248.150.10	241.040.70	241.060.90	246.030.60

- 可单独订购备件，按需询价
- 关于 BRA 系列刀座请参阅 P17

- The spare parts can be ordered separately. Please inquire on demand
- Please refer to P17 for BRA series Adaptor

## BRA-SC 系列滑块式刀夹

BRA-SC Series Sliding Cartridge

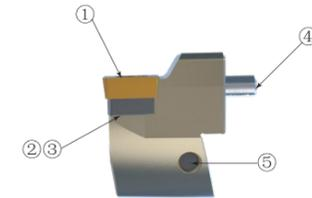

- SCMT SCGX SCMW
- 刀片仅做示意

- SCMT SCGX SCMW
- The insert is for illustration only

### 技术参数 | Technical parameters

单位 | Unit: mm

订货号 Ordering code	直径范围 Fitting Range	刀片 Insert	夹紧方式 Clamping
BPRA-SL-SC09-S-PA	35-45	SC.. 09T308	S
BPRA-SL-SC09-S-PB	35-45	SC.. 09T308	S
BPRA-SL-SC09-S-QA	45-55	SC.. 09T308	S
BPRA-SL-SC09-S-QB	45-55	SC.. 09T308	S
BPRA-SL-SC12-S-RA	55-70	SC.. 120408	S
BPRA-SL-SC12-S-RB	55-70	SC.. 120408	S
BPRA-SL-SC12-S-SA	70-85	SC.. 120408	S
BPRA-SL-SC12-S-SB	70-85	SC.. 120408	S
BPRA-SL-SC12-S-TA	85-105	SC.. 120408	S
BPRA-SL-SC12-S-TB	85-105	SC.. 120408	S
BPRA-SL-SC12-S-UA	105-130	SC.. 120408	S
BPRA-SL-SC12-S-UB	105-130	SC.. 120408	S
BPRA-SL-SC12-S-VA	130-160	SC.. 120408	S
BPRA-SL-SC12-S-VB	130-160	SC.. 120408	S

转下页 see next page →



## BRA-SC 系列滑块式刀夹

BRA-SC Series Sliding Cartridge

产品型号 Product ID	备件   Accessory					单独订购   Purchase Separately		
	①	②	③	④	⑤			
	刀片螺钉 Screw(Insert)	刀垫 Shim	刀片螺钉 Screw(Insert)	弹性销 Cotter	调整螺钉 Screw(Adj.)	刀片螺钉扳手 Key(Insert)	刀垫螺钉扳手 Key(Shim)	调整螺钉扳手 Key(Adj.)
BPRA-SL-SC09-S-PA	SFS 3581	-	-	179.025.08	-	248.150.10	-	-
BPRA-SL-SC09-S-PB	SFS 3581	-	-	179.025.08	-	248.150.10	-	-
BPRA-SL-SC09-S-QA	SFS 3581	-	-	-	253.030.10	248.150.10	-	246.015.60
BPRA-SL-SC09-S-QB	SFS 3581	-	-	-	253.030.10	248.150.10	-	246.015.60
BPRA-SL-SC12-S-RA	ILD 4011-A	-	-	-	253.040.12	248.150.10	-	246.020.60
BPRA-SL-SC12-S-RB	ILD 4011-A	-	-	-	253.040.12	248.150.10	-	246.020.60
BPRA-SL-SC12-S-SA	ILD 4014	322.420.02	512.090.03	-	253.050.12	248.150.10	241.040.70	246.025.60
BPRA-SL-SC12-S-SB	ILD 4014	322.420.02	512.090.03	-	253.050.12	248.150.10	241.040.70	246.025.60
BPRA-SL-SC12-S-TA	ILD 4014	322.420.02	512.090.03	-	253.060.16	248.150.10	241.040.70	246.030.60
BPRA-SL-SC12-S-TB	ILD 4014	322.420.02	512.090.03	-	253.060.16	248.150.10	241.040.70	246.030.60
BPRA-SL-SC12-S-UA	ILD 4014	322.420.02	512.090.03	179.060.16	-	248.150.10	241.040.70	-
BPRA-SL-SC12-S-UB	ILD 4014	322.420.02	512.090.03	179.060.16	-	248.150.10	241.040.70	-
BPRA-SL-SC12-S-VA	ILD 4014	322.420.02	512.090.03	179.060.16	-	248.150.10	241.040.70	-
BPRA-SL-SC12-S-VB	ILD 4014	322.420.02	512.090.03	179.060.16	-	248.150.10	241.040.70	-

• 可单独订购备件，按需询价

• The spare parts can be ordered separately. Please inquire on demand

## BRA 系列刀座

BRA series Adaptor



### 技术参数 | Technical parameters

单位 | Unit: mm

订货号 Ordering code	直径范围 Fitting Range	接口 Coupling
BPRA-CKB2-025024	25-35	CKB2
BPRA-CKB3-035026	35-45	CKB3
BPRA-A22A-045046	45-55	A22A
BPRA-A22A-055046	55-70	A22A
BPRA-A32A-070056	70-85	A32A
BPRA-A32A-085056	85-105	A32A
BPRA-A32A-105056	105-130	A32A
BPRA-A32A-130056	130-160	A32A

产品型号 Product ID	备件   Accessory					单独订购   Purchase Separately	
	① 螺钉 Screw(Lock)	② 弹簧垫圈 Shim	③ 调整螺钉 Screw(Adj.)	④ 堵丝 Nozzle	⑤ 水堵 Screw		
BPRA-CKB2-025024	113.030.10	136.030.03	253.025.08	251.020.02	-	241.025.56	241.013.40
BPRA-CKB3-035026	113.040.16	136.040.04	253.030.10	251.030.03	-	241.030.63	246.015.60
BPRA-A22A-045046	113.040.16	136.040.04	-	-	643.020.09	241.030.63	-
BPRA-A22A-055046	113.050.20	136.050.05	-	-	643.020.09	241.040.70	-
BPRA-A32A-070056	113.060.20	136.060.07	-	251.040.04	643.020.09	241.050.80	-
BPRA-A32A-085056	113.080.25	136.080.09	-	251.040.04	643.020.09	241.060.90	-
BPRA-A32A-105056	113.080.25	136.080.09	253.060.20	251.040.04	-	241.060.90	246.030.60
BPRA-A32A-130056	113.080.25	136.080.09	253.060.25	251.040.04	-	241.060.90	246.030.60

• 可单独订购备件，按需询价

• The spare parts can be ordered separately. Please inquire on demand

# 粗镗刀 BRB 系列

ROUGH-BORING BRB SERIES

## 01

适用于Φ160-Φ510mm的孔径加工  
Apply to Φ 160- Φ 510mm aperture machining

## 02

加工孔径公差±0.05  
Machining hole diameter  
tolerance ± 0.05

## 03

航空铝桥架具有较轻的重量可减少主轴负载

Aviation aluminum bridge with less weight can reduce the spindle load

## 05

可进行轴向及径向双向调节  
Bidirectional adjustment in axial and radial is available

## 04

刀夹装载ISO刀片，市场通用性好

The cartridge equipped with ISO inserts is with good market versidity



## BRB-CC-S 系列

BRB-CC-S Series

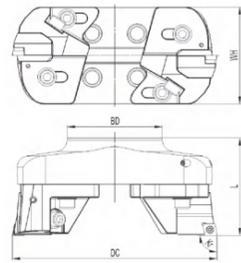

- 内冷却液供应
- CCMT CCGT CCGX CCET CCMW
- 刀片仅做示意

- Internal coolant supply
- CCMT CCGT CCGX CCET CCMW
- The insert is for illustration only

### 技术参数 | Technical parameters

单位 | Unit: mm

订货号 Ordering code	镗削范围   Boring Range(DC)			尺寸   Dimension					刀片 Insert	夹紧方式 Clamping	接口 Coupling
	Min.	Max.	Adj.	L	BD	WH	Kr	KG			
BRB-160215-CC12-S-A40C	160	215	27.5	105	100	104	90	4.39	CC.. 120408	S	A40C
BRB-215270-CC12-S-A40C	215	270	27.5	105	100	104	90	5.00	CC.. 120408	S	A40C

### 备件 | Accessory

产品型号 Product ID	①	②	③				
	桥架式刀座 Bridge Adaptor	滑块 Slide	刀夹 Cartridge	刀片螺钉扳手 Key(Insert)	刀垫螺钉扳手 Key(Shim)	锁紧螺钉扳手 Key(Screw)	调整螺钉扳手 Key(Adj.)
BRB-160215-CC12-S-A40C	BPDB-A40C-160050	BPRB-SL-160	BPRB-CA-CC12-S	248.150.10	241.040.70	241.080.00	246.030.60
BRB-215270-CC12-S-A40C	BPDB-A40C-215050	BPRB-SL-160	BPRB-CA-CC12-S	248.150.10	241.040.70	241.080.00	246.030.60

- 可单独订购备件，按需询价
- 关于 BRB 系列桥架式刀座请参阅 P43
- 关于 BRB 系列滑块请参阅 P45

- The spare parts can be ordered separately. Please inquire on demand
- Please refer to P43 for BRB series Bridge Adaptor
- Please refer to P45 for BRB series Sliding

## BRB-CC-S 系列

BRB-CC-S Series

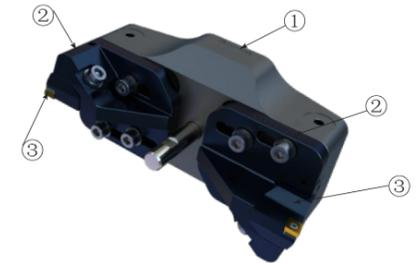
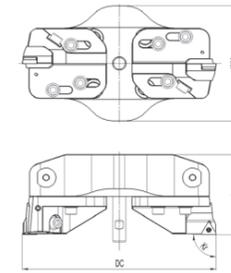

- 内冷却液供应
- CCMT CCGT CCGX CCET CCMW
- 刀片仅做示意

- Internal coolant supply
- CCMT CCGT CCGX CCET CCMW
- The insert is for illustration only

### 技术参数 | Technical parameters

单位 | Unit: mm

订货号 Ordering code	镗削范围   Boring Range(DC)			尺寸   Dimension					刀片 Insert	夹紧方式 Clamping	接口 Coupling
	Min.	Max.	Adj.	L	BD	WH	Kr	KG			
BRB-270350-CC12-S-A60C	270	350	40	115	-	140	90	7.8	CC.. 120408	S	A60C
BRB-350430-CC12-S-A60C	350	430	40	120	-	140	90	9.4	CC.. 120408	S	A60C
BRB-430510-CC12-S-A60C	430	510	40	125	-	140	90	11.1	CC.. 120408	S	A60C

### 备件 | Accessory

产品型号 Product ID	①	②	③				
	桥架式刀座 Bridge Adaptor	滑块 Slide	刀夹 Cartridge	刀片螺钉扳手 Key(Insert)	刀垫螺钉扳手 Key(Shim)	锁紧螺钉扳手 Key(Screw)	调整螺钉扳手 Key(Adj.)
BRB-270350-CC12-S-A60C	BPDB-A60C-270060	BPRB-SL-270	BPRB-CA-CC12-S	248.150.10	241.040.70	241.080.00	246.030.60
BRB-350430-CC12-S-A60C	BPDB-A60C-350065	BPRB-SL-270	BPRB-CA-CC12-S	248.150.10	241.040.70	241.080.00	246.030.60
BRB-430510-CC12-S-A60C	BPDB-A60C-430070	BPRB-SL-270	BPRB-CA-CC12-S	248.150.10	241.040.70	241.080.00	246.030.60

- 可单独订购备件，按需询价
- 关于 BRB 系列桥架式刀座请参阅 P44
- 关于 BRB 系列滑块请参阅 P45

- The spare parts can be ordered separately. Please inquire on demand
- Please refer to P44 for BRB series Bridge Adaptor
- Please refer to P45 for BRB series Sliding

## BRB-CC-S 系列刀夹

BRB-CC-S Series Cartridge

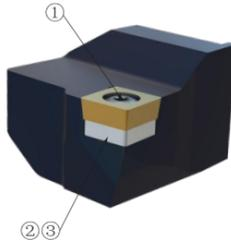

- CCMT CCGT CCGX CCET CCMW
- 刀片仅做示意

- CCMT CCGT CCGX CCET CCMW
- The insert is for illustration only

### > 技术参数 | Technical parameters

单位 | Unit: mm

订货号 Ordering code	刀片 Insert	夹紧方式 Coupling
BPRB-CA-CC12-S	CC..120408	S

### 备件 | Accessory

单独订购 | Purchase Separately

产品型号 Product ID	①	②	③	刀片螺钉扳手 Key(Insert)
	刀片螺钉 Screw(Insert)	刀垫 Shim	刀垫螺钉 Screw(Shim)	
BPRB-CA-CC12-S	ILD 4014	322.232.02	512.090.03	248.150.10

- 可单独订购备件，按需询价

- The spare parts can be ordered separately. Please inquire on demand

## BRB-TC-S 系列

BRB-TC-S Series

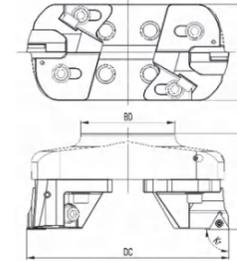

- 内冷却液供应
- TCMT TCMX TCGT TCGX TCEX TCMW
- 刀片仅做示意

- Internal coolant supply
- TCMT TCMX TCGT TCGX TCEX TCMW
- The insert is for illustration only

### > 技术参数 | Technical parameters

单位 | Unit: mm

订货号 Ordering code	镗削范围   Boring Range(DC)			尺寸   Dimension					刀片 Insert	夹紧方式 Clamping	接口 Coupling
	Min.	Max.	Adj.	L	BD	WH	Kr	KG			
BRB-160215-TC16-S-A40C	160	215	275	105	100	104	90	4.39	TC.. 16T308	S	A40C
BRB-215270-TC16-S-A40C	215	270	275	105	100	104	90	5.00	TC.. 16T308	S	A40C
BRB-160215-TC22-S-A40C	160	215	275	105	100	104	90	4.39	TC.. 220408	S	A40C
BRB-215270-TC22-S-A40C	215	270	275	105	100	104	90	5.00	TC.. 220408	S	A40C

### > 备件 | Accessory

产品型号 Product ID	①	②	③	刀片螺钉扳手 Key(Insert)	刀垫螺钉扳手 Key(Shim)	锁紧螺钉扳手 Key(Screw)	调整螺钉扳手 Key(Adj.)
	桥架式刀座 Bridge Adaptor	滑块 Slide	刀夹 Cartridge				
BRB-160215-TC16-S-A40C	BPDB-A40C-160050	BPRB-SL-160	BPRB-CA-TC16-S	248.150.10	241.035.65	241.080.00	246.030.60
BRB-215270-TC16-S-A40C	BPDB-A40C-215050	BPRB-SL-160	BPRB-CA-TC16-S	248.150.10	241.035.65	241.080.00	246.030.60
BRB-160215-TC22-S-A40C	BPDB-A40C-160050	BPRB-SL-160	BPRB-CA-TC22-S	248.150.10	241.040.70	241.080.00	246.030.60
BRB-215270-TC22-S-A40C	BPDB-A40C-215050	BPRB-SL-160	BPRB-CA-TC22-S	248.150.10	241.040.70	241.080.00	246.030.60

- 可单独订购备件，按需询价
- 关于 BRB 系列桥架式刀座请参阅 P43
- 关于 BRB 系列滑块请参阅 P45

- The spare parts can be ordered separately. Please inquire on demand
- Please refer to P43 for BRB series Bridge Adaptor
- Please refer to P45 for BRB series Sliding

## BRB-TC-S 系列

BRB-TC-S Series

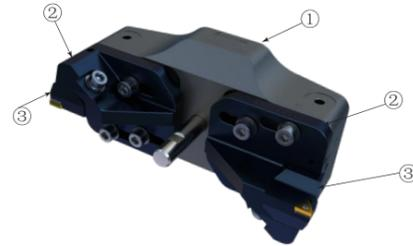
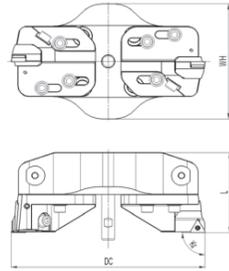

- 内冷却液供应
- TCMT TCMX TCGT TCGX TCEX TCMW
- 刀片仅做示意

- Internal coolant supply
- TCMT TCMX TCGT TCGX TCEX TCMW
- The insert is for illustration only

### 技术参数 | Technical parameters

单位 | Unit: mm

订货号 Ordering code	镗削范围   Boring Range(DC)			尺寸   Dimension					刀片 Insert	夹紧方式 Clamping	接口 Coupling
	Min.	Max.	Adj.	L	BD	WH	Kr	KG			
BRB-270350-TC16-S-A60C	270	350	40	115	-	140	90	7.8	TC..16T308	S	A60C
BRB-350430-TC16-S-A60C	350	430	40	120	-	140	90	9.4	TC..16T308	S	A60C
BRB-430510-TC16-S-A60C	430	510	40	125	-	140	90	11.1	TC..16T308	S	A60C
BRB-270350-TC22-S-A60C	270	350	40	115	-	140	90	7.8	TC..220408	S	A60C
BRB-350430-TC22-S-A60C	350	430	40	120	-	140	90	9.4	TC..220408	S	A60C
BRB-430510-TC22-S-A60C	430	510	40	125	-	140	90	11.1	TC..220408	S	A60C

### 备件 | Accessory

产品型号 Product ID	①	②	③				
	桥梁式刀座 Bridge Adaptor	滑块 Slide	刀夹 Cartridge	刀片螺钉扳手 Key(Insert)	刀垫螺钉扳手 Key(Shim)	锁紧螺钉扳手 Key(Screw)	锁紧螺钉扳手 Key(Adj.)
BRB-270350-TC16-S-A60C	BPDB-A60C-270060	BPRB-SL-270	BPRB-CA-TC16-S	248.150.10	241.035.65	241.080.00	246.030.60
BRB-350430-TC16-S-A60C	BPDB-A60C-350065	BPRB-SL-270	BPRB-CA-TC16-S	248.150.10	241.035.65	241.080.00	246.030.60
BRB-430510-TC16-S-A60C	BPDB-A60C-430070	BPRB-SL-270	BPRB-CA-TC16-S	248.150.10	241.035.65	241.080.00	246.030.60
BRB-270350-TC22-S-A60C	BPDB-A60C-270060	BPRB-SL-270	BPRB-CA-TC22-S	248.150.10	241.040.70	241.080.00	246.030.60
BRB-350430-TC22-S-A60C	BPDB-A60C-350065	BPRB-SL-270	BPRB-CA-TC22-S	248.150.10	241.040.70	241.080.00	246.030.60
BRB-430510-TC22-S-A60C	BPDB-A60C-430070	BPRB-SL-270	BPRB-CA-TC22-S	248.150.10	241.040.70	241.080.00	246.030.60

- 可单独订购备件，按需询价
- 关于 BRB 系列桥梁式刀座请参阅 P44
- 关于 BRB 系列滑块请参阅 P45

- The spare parts can be ordered separately. Please inquire on demand
- Please refer to P44 for BRB series Bridge Adaptor
- Please refer to P45 for BRB series Sliding

## BRB-TC-S 系列刀夹

BRB-TC-S Series Cartridge

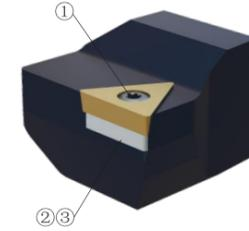

- TCMT TCMX TCGT TCGX TCEX TCMW
- 刀片仅做示意

- TCMT TCMX TCGT TCGX TCEX TCMW
- The insert is for illustration only

### 技术参数 | Technical parameters

单位 | Unit: mm

订货号 Ordering code	刀片 Insert	夹紧方式 Coupling
BPRB-CA-TC16-S	TC..16T308	S
BPRB-CA-TC22-S	TC..220408	S

### 备件 | Accessory

单独订购 | Purchase Separately

产品型号 Product ID	①	②	③	
	刀片螺钉 Screw(Insert)	刀垫 Shim	刀垫螺钉 Screw(Shim)	刀片螺钉扳手 Key(Insert)
BPRB-CA-TC16-S	SF5_3512	322.320.01	512.090.01	248.150.10
BPRB-CA-TC22-S	ILD 4014	322.320.02	512.090.03	248.150.10

- 可单独订购备件，按需询价

- The spare parts can be ordered separately. Please inquire on demand

## BRB-SC-S 系列

BRB-SC-S Series

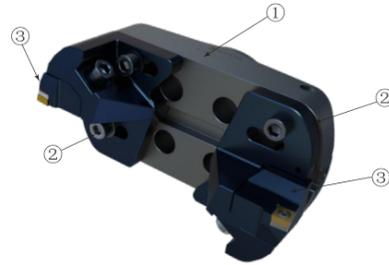
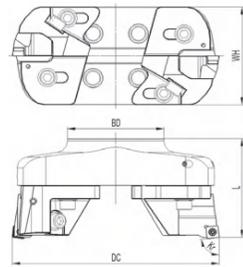

- 内冷却液供应
- SCMT SCGX SCMW
- 刀片仅做示意

- Internal coolant supply
- SCMT SCGX SCMW
- The insert is for illustration only

### 技术参数 | Technical parameters

单位 | Unit: mm

订货号 Ordering code	镗削范围   Boring Range(DC)			尺寸   Dimension					刀片 Insert	夹紧方式 Clamping	接口 Coupling
	Min.	Max.	Adj.	L	BD	WH	Kr	KG			
BRB-160215-SC12-S-A40C	160	215	27.5	105	100	104	84	4.39	SC.. 120408	S	A40C
BRB-215270-SC12-S-A40C	215	270	27.5	105	100	104	84	5.00	SC.. 120408	S	A40C

### 备件 | Accessory

产品型号 Product ID	①	②	③				
	桥架式刀座 Bridge Adaptor	滑块 Slide	刀夹 Cartridge	刀片螺钉扳手 Key(Insert)	刀垫螺钉扳手 Key(Shim)	锁紧螺钉扳手 Key(Screw)	调整螺钉扳手 Key(Adj.)
BRB-160215-SC12-S-A40C	BPDB-A40C-160050	BPRB-SL-160	BPRB-CA-SC12-S	248.150.10	241.040.70	241.080.00	246.030.60
BRB-215270-SC12-S-A40C	BPDB-A40C-215050	BPRB-SL-160	BPRB-CA-SC12-S	248.150.10	241.040.70	241.080.00	246.030.60

- 可单独订购备件，按需询价
- 关于 BRB 系列桥架式刀座请参阅 P43
- 关于 BRB 系列滑块请参阅 P45

- The spare parts can be ordered separately. Please inquire on demand
- Please refer to P43 for BRB series Bridge Adaptor
- Please refer to P45 for BRB series Sliding

## BRB-SC-S 系列

BRB-SC-S Series

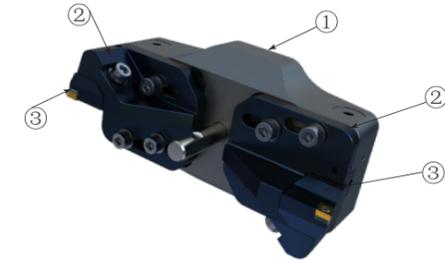
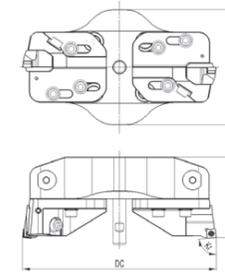

- 内冷却液供应
- SCMT SCGX SCMW
- 刀片仅做示意

- Internal coolant supply
- SCMT SCGX SCMW
- The insert is for illustration only

### 技术参数 | Technical parameters

单位 | Unit: mm

订货号 Ordering code	镗削范围   Boring Range(DC)			尺寸   Dimension					刀片 Insert	夹紧方式 Clamping	接口 Coupling
	Min.	Max.	Adj.	L	BD	WH	Kr	KG			
BRB-270350-SC12-S-A60C	270	350	40	115	-	140	84	7.8	SC.. 120408	S	A60C
BRB-350430-SC12-S-A60C	350	430	40	120	-	140	84	9.4	SC.. 120408	S	A60C
BRB-430510-SC12-S-A60C	430	510	40	125	-	140	84	11.1	SC.. 120408	S	A60C

### 备件 | Accessory

产品型号 Product ID	①	②	③				
	桥架式刀座 Bridge Adaptor	滑块 Slide	刀夹 Cartridge	刀片螺钉扳手 Key(Insert)	刀垫螺钉扳手 Key(Shim)	锁紧螺钉扳手 Key(Screw)	调整螺钉扳手 Key(Adj.)
BRB-270350-SC12-S-A60C	BPDB-A60C-270060	BPRB-SL-270	BPRB-CA-SC12-S	248.150.10	241.040.70	241.080.00	246.030.60
BRB-350430-SC12-S-A60C	BPDB-A60C-350065	BPRB-SL-270	BPRB-CA-SC12-S	248.150.10	241.040.70	241.080.00	246.030.60
BRB-430510-SC12-S-A60C	BPDB-A60C-430070	BPRB-SL-270	BPRB-CA-SC12-S	248.150.10	241.040.70	241.080.00	246.030.60

- 可单独订购备件，按需询价
- 关于 BRB 系列桥架式刀座请参阅 P44
- 关于 BRB 系列滑块请参阅 P45

- The spare parts can be ordered separately. Please inquire on demand
- Please refer to P44 for BRB series Bridge Adaptor
- Please refer to P45 for BRB series Sliding

## BRB-SC-S 系列刀夹

BRB-SC-S Series Cartridge

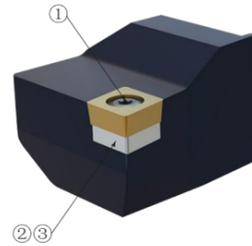

- SCMT SCGX SCMW
- 刀片仅做示意
- SCMT SCGX SCMW
- The insert is for illustration only

### > 技术参数 | Technical parameters

单位 | Unit: mm

订货号 Ordering code	刀片 Insert	夹紧方式 Coupling
BPRB-CA-SC12-S	SC..120408	S

产品型号 Product ID	备件   Accessory			单独订购   Purchase Separately
	① 刀片螺钉 Screw(Insert)	② 刀垫 Shim	③ 刀垫螺钉 Screw(Shim)	
BPRB-CA-SC12-S	ILD 4014	322.420.02	512.090.03	248.150.10

- 可单独订购备件，按需询价
- The spare parts can be ordered separately. Please inquire on demand

## BRB-CN-D 系列

BRB-CN-D Series

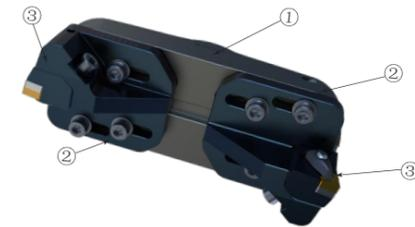
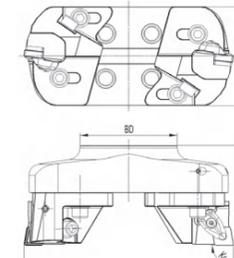

- 内冷却液供应
- CNMM CNMG CNMA CNGA
- 刀片仅做示意
- Internal coolant supply
- CNMM CNMG CNMA CNGA
- The insert is for illustration only

### > 技术参数 | Technical parameters

单位 | Unit: mm

订货号 Ordering code	镗削范围   Boring Range(DC)			尺寸   Dimension					刀片 Insert	夹紧方式 Clamping	接口 Coupling
	Min.	Max.	Adj.	L	BD	WH	Kr	KG			
BRB-160215-CN12-D-A40C	160	215	275	105	100	104	90	4.39	CN.. 120408	D	A40C
BRB-215270-CN12-D-A40C	215	270	275	105	100	104	90	5.00	CN.. 120408	D	A40C
BRB-160215-CN16-D-A40C	160	215	275	105	100	104	90	4.39	CN.. 160612	D	A40C
BRB-215270-CN16-D-A40C	215	270	275	105	100	104	90	5.00	CN.. 160612	D	A40C
BRB-160215-CN19-D-A40C	160	215	275	105	100	104	90	4.39	CN.. 190612	D	A40C
BRB-215270-CN19-D-A40C	215	270	275	105	100	104	90	5.00	CN.. 190612	D	A40C

### > 备件 | Accessory

产品型号 Product ID	①	②	③	刀片螺钉扳手 Key(Insert)	锁紧螺钉扳手 Key(Screw)	调整螺钉扳手 Key(Adj.)
	桥架式刀座 Bridge Adaptor	滑块 Slide	刀夹 Cartridge			
BRB-160215-CN12-D-A40C	BPDB-A40C-160050	BPRB-SL-160	BPRB-CA-CN12-D	248.150.10	241.080.00	246.030.60
BRB-215270-CN12-D-A40C	BPDB-A40C-215050	BPRB-SL-160	BPRB-CA-CN12-D	248.150.10	241.080.00	246.030.60
BRB-160215-CN16-D-A40C	BPDB-A40C-160050	BPRB-SL-160	BPRB-CA-CN16-D	248.200.10	241.080.00	246.030.60
BRB-215270-CN16-D-A40C	BPDB-A40C-215050	BPRB-SL-160	BPRB-CA-CN16-D	248.200.10	241.080.00	246.030.60
BRB-160215-CN19-D-A40C	BPDB-A40C-160050	BPRB-SL-160	BPRB-CA-CN19-D	248.200.10	241.080.00	246.030.60
BRB-215270-CN19-D-A40C	BPDB-A40C-215050	BPRB-SL-160	BPRB-CA-CN19-D	248.200.10	241.080.00	246.030.60

- 可单独订购备件，按需询价
- 关于 BRB 系列桥架式刀座请参阅 P43
- 关于 BRB 系列滑块请参阅 P45
- The spare parts can be ordered separately. Please inquire on demand
- Please refer to P43 for BRB series Bridge Adaptor
- Please refer to P45 for BRB series Sliding

## BRB-CN-D 系列

BRB-CN-D Series

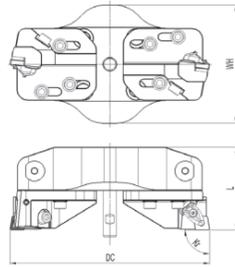

- 内冷却液供应
- CNMM CNMG CNMA CNGA
- 刀片仅做示意

- Internal coolant supply
- CNMM CNMG CNMA CNGA
- The insert is for illustration only

### 技术参数 | Technical parameters

单位 | Unit: mm

订货号 Ordering code	镗削范围   Boring Range(DC)			尺寸   Dimension					刀片 Insert	夹紧方式 Clamping	接口 Coupling
	Min.	Max.	Adj.	L	BD	WH	Kr	KG			
BRB-270350-CN12-D-A60C	270	350	40	115	-	140	90	7.8	CN.. 120408	D	A60C
BRB-350430-CN12-D-A60C	350	430	40	120	-	140	90	9.4	CN.. 120408	D	A60C
BRB-430510-CN12-D-A60C	430	510	40	125	-	140	90	11.1	CN.. 120408	D	A60C
BRB-270350-CN16-D-A60C	270	350	40	115	-	140	90	7.8	CN.. 160612	D	A60C
BRB-350430-CN16-D-A60C	350	430	40	120	-	140	90	9.4	CN.. 160612	D	A60C
BRB-430510-CN16-D-A60C	430	510	40	125	-	140	90	11.1	CN.. 160612	D	A60C
BRB-270350-CN19-D-A60C	270	350	40	115	-	140	90	7.8	CN.. 190612	D	A60C
BRB-350430-CN19-D-A60C	350	430	40	120	-	140	90	9.4	CN.. 190612	D	A60C
BRB-430510-CN19-D-A60C	430	510	40	125	-	140	90	11.1	CN.. 190612	D	A60C

转下页 see next page →

## BRB-CN-D 系列

BRB-CN-D Series

### 备件 | Accessory

产品型号 Product ID	①	②	③			
	桥架式刀座 Bridge Adaptor	滑块 Slide	刀夹 Cartridge	刀片螺钉扳手 Key(Insert)	锁紧螺钉扳手 Key(Screw)	调整螺钉扳手 Key(Adj.)
BRB-270350-CN12-D-A60C	BPDB-A60C-270060	BPRB-SL-270	BPRB-CA-CN12-D	248.150.10	241.080.00	246.030.60
BRB-350430-CN12-D-A60C	BPDB-A60C-350065	BPRB-SL-270	BPRB-CA-CN12-D	248.150.10	241.080.00	246.030.60
BRB-430510-CN12-D-A60C	BPDB-A60C-430070	BPRB-SL-270	BPRB-CA-CN12-D	248.150.10	241.080.00	246.030.60
BRB-270350-CN16-D-A60C	BPDB-A60C-270060	BPRB-SL-270	BPRB-CA-CN16-D	248.200.10	241.080.00	246.030.60
BRB-350430-CN16-D-A60C	BPDB-A60C-350065	BPRB-SL-270	BPRB-CA-CN16-D	248.200.10	241.080.00	246.030.60
BRB-430510-CN16-D-A60C	BPDB-A60C-430070	BPRB-SL-270	BPRB-CA-CN16-D	248.200.10	241.080.00	246.030.60
BRB-270350-CN19-D-A60C	BPDB-A60C-270060	BPRB-SL-270	BPRB-CA-CN19-D	248.200.10	241.080.00	246.030.60
BRB-350430-CN19-D-A60C	BPDB-A60C-350065	BPRB-SL-270	BPRB-CA-CN19-D	248.200.10	241.080.00	246.030.60
BRB-430510-CN19-D-A60C	BPDB-A60C-430070	BPRB-SL-270	BPRB-CA-CN19-D	248.200.10	241.080.00	246.030.60

- 可单独订购备件，按需询价
- 关于 BRB 系列桥架式刀座请参阅 P44
- 关于 BRB 系列滑块请参阅 P45

- The spare parts can be ordered separately. Please inquire on demand
- Please refer to P44 for BRB series Bridge Adaptor
- Please refer to P45 for BRB series Sliding



## BRB-CN-D 系列刀夹

BRB-CN-D Series Cartridge

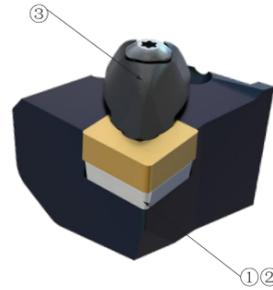

- CNMM CNMG CNMA CNGA
- 刀片仅做示意

- CNMM CNMG CNMA CNGA
- The insert is for illustration only

### 技术参数 | Technical parameters

单位 | Unit: mm

订货号 Ordering code	刀片 Insert	夹紧方式 Coupling
BPRB-CA-CN12-D	CN..120408	D
BPRB-CA-CN16-D	CN..160612	D
BPRB-CA-CN19-D	CN..190612	D

产品型号 Product ID	备件   Accessory			单独订购   Purchase Separately
	① 刀片螺钉 Screw(Insert)	② 刀垫 Shim	③ 刀垫螺钉 Screw(Shim)	刀片螺钉扳手 Key(Insert)
BPRB-CA-CN12-D	322.236.03	SFS 4085	412.028.21	248.150.10
BPRB-CA-CN16-D	322.234.03	SFS 5011	412.028.31	248.200.10
BPRB-CA-CN19-D	322.236.01	SFS 5011	412.028.41	248.200.10

- 可单独订购备件，按需询价

- The spare parts can be ordered separately. Please inquire on demand

## BRB-SN-D 系列

BRB-SN-D Series

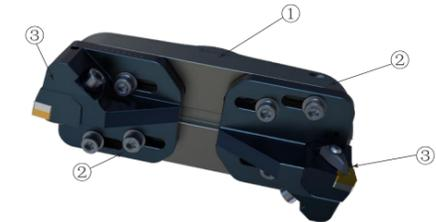
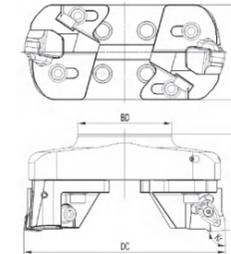

- 内冷却液供应
- SNMM SNMG SNMA SNGA
- 刀片仅做示意

- Internal coolant supply
- SNMM SNMG SNMA SNGA
- The insert is for illustration only

### 技术参数 | Technical parameters

单位 | Unit: mm

订货号 Ordering code	镗削范围   Boring Range(DC)			尺寸   Dimension					刀片 Insert	夹紧方式 Clamping	接口 Coupling
	Min.	Max.	Adj.	L	BD	WH	Kr	KG			
BRB-160215-SN12-D-A40C	160	215	275	105	100	104	84	4.39	SN.. 120408	D	A40C
BRB-215270-SN12-D-A40C	215	270	275	105	100	104	84	5.00	SN.. 120408	D	A40C
BRB-160215-SN15-D-A40C	160	215	275	105	100	104	84	4.39	SN.. 150612	D	A40C
BRB-215270-SN15-D-A40C	215	270	275	105	100	104	84	5.00	SN.. 150612	D	A40C

### 备件 | Accessory

产品型号 Product ID	①	②	③	刀片螺钉扳手 Key(Insert)	锁紧螺钉扳手 Key(Screw)	调整螺钉扳手 Key(Adj.)
	桥架式刀座 Bridge Adaptor	滑块 Slide	刀夹 Cartridge			
BRB-160215-SN12-D-A40C	BPDB-A40C-160050	BPRB-SL-160	BPRB-CA-SN12-D	248.150.10	241.080.00	246.030.60
BRB-215270-SN12-D-A40C	BPDB-A40C-215050	BPRB-SL-160	BPRB-CA-SN12-D	248.150.10	241.080.00	246.030.60
BRB-160215-SN15-D-A40C	BPDB-A40C-160050	BPRB-SL-160	BPRB-CA-SN15-D	248.200.10	241.080.00	246.030.60
BRB-215270-SN15-D-A40C	BPDB-A40C-215050	BPRB-SL-160	BPRB-CA-SN15-D	248.200.10	241.080.00	246.030.60

- 可单独订购备件，按需询价
- 关于 BRB 系列桥架式刀座请参阅 P43
- 关于 BRB 系列滑块请参阅 P45

- The spare parts can be ordered separately. Please inquire on demand
- Please refer to P43 for BRB series Bridge Adaptor
- Please refer to P45 for BRB series Sliding

## BRB-SN-D 系列

BRB-SN-D Series



- 内冷却液供应
- SNMM SNMG SNMA SNGA
- 刀片仅做示意

- Internal coolant supply
- SNMM SNMG SNMA SNGA
- The insert is for illustration only

### 技术参数 | Technical parameters

单位 | Unit: mm

订货号 Ordering code	镗削范围   Boring Range(DC)			尺寸   Dimension					刀片 Insert	夹紧方式 Clamping	接口 Coupling
	Min.	Max.	Adj.	L	BD	WH	Kr	KG			
BRB-270350-SN12-D-A60C	270	350	40	115	-	140	84	7.8	SN.. 120408	D	A60C
BRB-350430-SN12-D-A60C	350	430	40	120	-	140	84	9.4	SN.. 120408	D	A60C
BRB-430510-SN12-D-A60C	430	510	40	125	-	140	84	11.1	SN.. 120408	D	A60C
BRB-270350-SN15-D-A60C	270	350	40	115	-	140	84	7.8	SN.. 150612	D	A60C
BRB-350430-SN15-D-A60C	350	430	40	120	-	140	84	9.4	SN.. 150612	D	A60C
BRB-430510-SN15-D-A60C	430	510	40	125	-	140	84	11.1	SN.. 150612	D	A60C

### 备件 | Accessory

产品型号 Product ID	①	②	③			
	桥架式刀座 Bridge Adaptor	滑块 Slide	刀夹 Cartridge	刀片螺钉扳手 Key(Insert)	锁紧螺钉扳手 Key(Screw)	调整螺钉扳手 Key(Adj.)
BRB-270350-SN12-D-A60C	BPDB-A60C-270060	BPRB-SL-270	BPRB-CA-SN12-D	248.150.10	241.080.00	246.030.60
BRB-350430-SN12-D-A60C	BPDB-A60C-350065	BPRB-SL-270	BPRB-CA-SN12-D	248.150.10	241.080.00	246.030.60
BRB-430510-SN12-D-A60C	BPDB-A60C-430070	BPRB-SL-270	BPRB-CA-SN12-D	248.150.10	241.080.00	246.030.60
BRB-270350-SN15-D-A60C	BPDB-A60C-270060	BPRB-SL-270	BPRB-CA-SN15-D	248.200.10	241.080.00	246.030.60
BRB-350430-SN15-D-A60C	BPDB-A60C-350065	BPRB-SL-270	BPRB-CA-SN15-D	248.200.10	241.080.00	246.030.60
BRB-430510-SN15-D-A60C	BPDB-A60C-430070	BPRB-SL-270	BPRB-CA-SN15-D	248.200.10	241.080.00	246.030.60

- 可单独订购备件，按需询价
- 关于 BRB 系列桥架式刀座请参阅 P44
- 关于 BRB 系列滑块请参阅 P45

- The spare parts can be ordered separately. Please inquire on demand
- Please refer to P44 for BRB series Bridge Adaptor
- Please refer to P45 for BRB series Sliding

## BRB-SN-D 系列刀夹

BRB-SN-D Series Cartridge

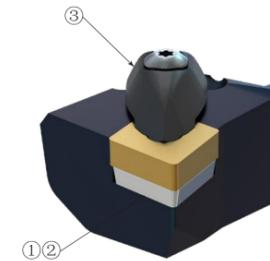

- SNMM SNMG SNMA SNGA
- 刀片仅做示意

- SNMM SNMG SNMA SNGA
- The insert is for illustration only

### 技术参数 | Technical parameters

单位 | Unit: mm

订货号 Ordering code	刀片 Insert	夹紧方式 Coupling
BPRB-CA-SN12-D	SN..120408	D
BPRB-CA-SN15-D	SN..150612	D

备件 | Accessory

单独订购 | Purchase Separately

产品型号 Product ID	①	②	③	
	刀垫 Shim	刀垫螺钉 Screw(Shim)	压板组件 Clamp Set	刀片螺钉扳手 Key(Insert)
BPRB-CA-SN12-D	322.426.02	SFS 4085	412.028.21	248.150.10
BPRB-CA-SN15-D	322.425.03	SFS 5011	412.028.31	248.200.10

- 可单独订购备件，按需询价

- The spare parts can be ordered separately. Please inquire on demand

## BRB-CN-P 系列

BRB-CN-P Series

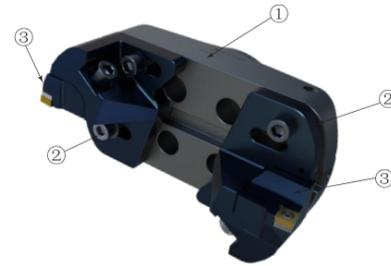
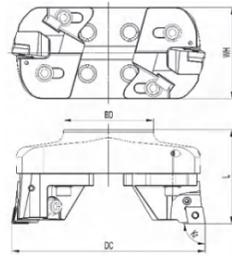

- 内冷却液供应
- CNMM CNMG CNMA CNGA
- 刀片仅做示意

- Internal coolant supply
- CNMM CNMG CNMA CNGA
- The insert is for illustration only

### 技术参数 | Technical parameters

单位 | Unit: mm

订货号 Ordering code	镗削范围   Boring Range(DC)			尺寸   Dimension					刀片 Insert	夹紧方式 Clamping	接口 Coupling
	Min.	Max.	Adj.	L	BD	WH	Kr	KG			
BRB-160215-CN12-P-A40C	160	215	27.5	105	100	104	90	4.39	CN..120408	P	A40C
BRB-215270-CN12-P-A40C	215	270	27.5	105	100	104	90	5.00	CN..120408	P	A40C
BRB-160215-CN16-P-A40C	160	215	27.5	105	100	104	90	4.39	CN..160612	P	A40C
BRB-215270-CN16-P-A40C	215	270	27.5	105	100	104	90	5.00	CN..160612	P	A40C
BRB-160215-CN19-P-A40C	160	215	27.5	105	100	104	90	4.39	CN..190612	P	A40C
BRB-215270-CN19-P-A40C	215	270	27.5	105	100	104	90	5.00	CN..190612	P	A40C

### 备件 | Accessory

产品型号 Product ID	①	②	③			
	桥架式刀座 Bridge Adaptor	滑块 Slide	刀夹 Cartridge	刀片螺钉扳手 Key(Insert)	锁紧螺钉扳手 Key(Screw)	调整螺钉扳手 Key(Adj.)
BRB-160215-CN12-P-A40C	BPDB-A40C-160050	BPRB-SL-160	BPRB-CA-CN12-P	241.030.63	241.080.00	246.030.60
BRB-215270-CN12-P-A40C	BPDB-A40C-215050	BPRB-SL-160	BPRB-CA-CN12-P	241.030.63	241.080.00	246.030.60
BRB-160215-CN16-P-A40C	BPDB-A40C-160050	BPRB-SL-160	BPRB-CA-CN16-P	241.030.63	241.080.00	246.030.60
BRB-215270-CN16-P-A40C	BPDB-A40C-215050	BPRB-SL-160	BPRB-CA-CN16-P	241.030.63	241.080.00	246.030.60
BRB-160215-CN19-P-A40C	BPDB-A40C-160050	BPRB-SL-160	BPRB-CA-CN19-P	241.040.70	241.080.00	246.030.60
BRB-215270-CN19-P-A40C	BPDB-A40C-215050	BPRB-SL-160	BPRB-CA-CN19-P	241.040.70	241.080.00	246.030.60

- 可单独订购备件，按需询价
- 关于 BRB 系列桥架式刀座请参阅 P43
- 关于 BRB 系列滑块请参阅 P45

- The spare parts can be ordered separately. Please inquire on demand
- Please refer to P43 for BRB series Bridge Adaptor
- Please refer to P45 for BRB series Sliding

## BRB-CN-P 系列

BRB-CN-P Series

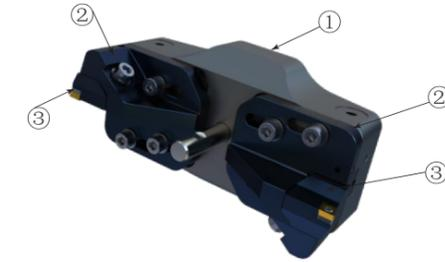
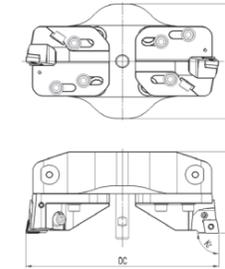

- 内冷却液供应
- CNMM CNMG CNMA CNGA
- 刀片仅做示意

- Internal coolant supply
- CNMM CNMG CNMA CNGA
- The insert is for illustration only

### 技术参数 | Technical parameters

单位 | Unit: mm

订货号 Ordering code	镗削范围   Boring Range(DC)			尺寸   Dimension					刀片 Insert	夹紧方式 Clamping	接口 Coupling
	Min.	Max.	Adj.	L	BD	WH	Kr	KG			
BRB-270350-CN12-P-A60C	270	350	40	115	-	140	90	7.8	CN..120408	P	A60C
BRB-350430-CN12-P-A60C	350	430	40	120	-	140	90	9.4	CN..120408	P	A60C
BRB-430510-CN12-P-A60C	430	510	40	125	-	140	90	11.1	CN..120408	P	A60C
BRB-270350-CN16-P-A60C	270	350	40	115	-	140	90	7.8	CN..160612	P	A60C
BRB-350430-CN16-P-A60C	350	430	40	120	-	140	90	9.4	CN..160612	P	A60C
BRB-430510-CN16-P-A60C	430	510	40	125	-	140	90	11.1	CN..160612	P	A60C
BRB-270350-CN19-P-A60C	270	350	40	117	-	140	90	7.8	CN..190612	P	A60C
BRB-350430-CN19-P-A60C	350	430	40	122	-	140	90	9.4	CN..190612	P	A60C
BRB-430510-CN19-P-A60C	430	510	40	127	-	140	90	11.1	CN..190612	P	A60C

转下页 see next page →

## BRB-CN-P 系列

BRB-CN-P Series

### > 备件 | Accessory

产品型号 Product ID	①	②	③			
	桥架式刀座 Bridge Adaptor	滑块 Slide	刀夹 Cartridge	刀片螺钉扳手 Key(Insert)	锁紧螺钉扳手 Key(Screw)	调整螺钉扳手 Key(Adj.)
BRB-270350-CN12-P-A60C	BPDB-A60C-270060	BPRB-SL-270	BPRB-CA-CN12-P	241.030.63	241.080.00	246.030.60
BRB-350430-CN12-P-A60C	BPDB-A60C-350065	BPRB-SL-270	BPRB-CA-CN12-P	241.030.63	241.080.00	246.030.60
BRB-430510-CN12-P-A60C	BPDB-A60C-430070	BPRB-SL-270	BPRB-CA-CN12-P	241.030.63	241.080.00	246.030.60
BRB-270350-CN16-P-A60C	BPDB-A60C-270060	BPRB-SL-270	BPRB-CA-CN16-P	241.030.63	241.080.00	246.030.60
BRB-350430-CN16-P-A60C	BPDB-A60C-350065	BPRB-SL-270	BPRB-CA-CN16-P	241.030.63	241.080.00	246.030.60
BRB-430510-CN16-P-A60C	BPDB-A60C-430070	BPRB-SL-270	BPRB-CA-CN16-P	241.030.63	241.080.00	246.030.60
BRB-270350-CN19-P-A60C	BPDB-A60C-270060	BPRB-SL-270	BPRB-CA-CN19-P	241.040.70	241.080.00	246.030.60
BRB-350430-CN19-P-A60C	BPDB-A60C-350065	BPRB-SL-270	BPRB-CA-CN19-P	241.040.70	241.080.00	246.030.60
BRB-430510-CN19-P-A60C	BPDB-A60C-430070	BPRB-SL-270	BPRB-CA-CN19-P	241.040.70	241.080.00	246.030.60

- 可单独订购备件，按需询价
- 关于 BRB 系列桥架式刀座请参阅 P44
- 关于 BRB 系列滑块请参阅 P45

- The spare parts can be ordered separately. Please inquire on demand
- Please refer to P44 for BRB series Bridge Adaptor
- Please refer to P45 for BRB series Sliding

## BRB-CN-P 系列刀夹

BRB-CN-P Series Cartridge

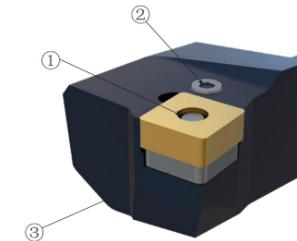

- CNMM CNMG CNMA CNGA
- 刀片仅做示意

- CNMM CNMG CNMA CNGA
- The insert is for illustration only

### > 技术参数 | Technical parameters

单位 | Unit: mm

订货号 Ordering code	刀片 Insert	夹紧方式 Coupling
BPRB-CA-CN12-P	CN..120408	P
BPRB-CA-CN16-P	CN..160612	P
BPRB-CA-CN19-P	CN..190612	P

产品型号 Product ID	备件   Accessory			单独订购   Purchase Separately
	① 杠杆 Lever	② 螺钉 Screw	③ 刀垫 Shim	 扳手 Key
BPRB-CA-CN12-P	413.438.41	414.438.21	322.318.50	241.030.63
BPRB-CA-CN16-P	413.838.40	414.838.31	322.318.52	241.030.63
BPRB-CA-CN19-P	413.438.42	414.438.22	322.318.51	241.040.70

- 可单独订购备件，按需询价

- The spare parts can be ordered separately. Please inquire on demand

## BRB-SN-P 系列

BRB-SN-P Series



- 内冷却液供应
- SNMM SNMG SNMA SNGA
- 刀片仅做示意

- Internal coolant supply
- SNMM SNMG SNMA SNGA
- The insert is for illustration only

### 技术参数 | Technical parameters

单位 | Unit: mm

订货号 Ordering code	镗削范围   Boring Range(DC)			尺寸   Dimension					刀片 Insert	夹紧方式 Clamping	接口 Coupling
	Min.	Max.	Adj.	L	BD	WH	Kr	KG			
BRB-160215-SN12-P-A40C	160	215	27.5	105	100	104	84	4.39	SN..120408	P	A40C
BRB-215270-SN12-P-A40C	215	270	27.5	105	100	104	84	5.00	SN..120408	P	A40C
BRB-160215-SN15-P-A40C	160	215	27.5	105	100	104	84	4.39	SN..150612	P	A40C
BRB-215270-SN15-P-A40C	215	270	27.5	105	100	104	84	5.00	SN..150612	P	A40C

### 备件 | Accessory

产品型号 Product ID	①	②	③			
	桥架式刀座 Bridge Adaptor	滑块 Slide	刀夹 Cartridge	刀片螺钉扳手 Key(Insert)	锁紧螺钉扳手 Key(Screw)	调整螺钉扳手 Key(Adj.)
BRB-160215-SN12-P-A40C	BPDB-A40C-160050	BPRB-SL-160	BPRB-CA-SN12-P	241.030.63	241.080.00	246.030.60
BRB-215270-SN12-P-A40C	BPDB-A40C-215050	BPRB-SL-160	BPRB-CA-SN12-P	241.030.63	241.080.00	246.030.60
BRB-160215-SN15-P-A40C	BPDB-A40C-160050	BPRB-SL-160	BPRB-CA-SN15-P	241.030.63	241.080.00	246.030.60
BRB-215270-SN15-P-A40C	BPDB-A40C-215050	BPRB-SL-160	BPRB-CA-SN15-P	241.030.63	241.080.00	246.030.60

- 可单独订购备件，按需询价
- 关于 BRB 系列桥架式刀座请参阅 P43
- 关于 BRB 系列滑块请参阅 P45

- The spare parts can be ordered separately. Please inquire on demand
- Please refer to P43 for BRB series Bridge Adaptor
- Please refer to P45 for BRB series Sliding

## BRB-SN-P 系列

BRB-SN-P Series



- 内冷却液供应
- SNMM SNMG SNMA SNGA
- 刀片仅做示意

- Internal coolant supply
- SNMM SNMG SNMA SNGA
- The insert is for illustration only

### 技术参数 | Technical parameters

单位 | Unit: mm

订货号 Ordering code	镗削范围   Boring Range(DC)			尺寸   Dimension					刀片 Insert	夹紧方式 Clamping	接口 Coupling
	Min.	Max.	Adj.	L	BD	WH	Kr	KG			
BRB-270350-SN12-P-A60C	270	350	40	115	-	140	84	7.8	SN..120408	P	A60C
BRB-350430-SN12-P-A60C	350	430	40	120	-	140	84	9.4	SN..120408	P	A60C
BRB-430510-SN12-P-A60C	430	510	40	125	-	140	84	11.1	SN..120408	P	A60C
BRB-270350-SN15-P-A60C	270	350	40	115	-	140	84	7.8	SN..150612	P	A60C
BRB-350430-SN15-P-A60C	350	430	40	120	-	140	84	9.4	SN..150612	P	A60C
BRB-430510-SN15-P-A60C	430	510	40	125	-	140	84	11.1	SN..150612	P	A60C

### 备件 | Accessory

产品型号 Product ID	①	②	③			
	桥架式刀座 Bridge Adaptor	滑块 Slide	刀夹 Cartridge	刀片螺钉扳手 Key(Insert)	锁紧螺钉扳手 Key(Screw)	调整螺钉扳手 Key(Adj.)
BRB-270350-SN12-P-A60C	BPDB-A60C-270060	BPRB-SL-270	BPRB-CA-SN12-P	241.030.63	241.080.00	246.030.60
BRB-350430-SN12-P-A60C	BPDB-A60C-350065	BPRB-SL-270	BPRB-CA-SN12-P	241.030.63	241.080.00	246.030.60
BRB-430510-SN12-P-A60C	BPDB-A60C-430070	BPRB-SL-270	BPRB-CA-SN12-P	241.030.63	241.080.00	246.030.60
BRB-270350-SN15-P-A60C	BPDB-A60C-270060	BPRB-SL-270	BPRB-CA-SN15-P	241.030.63	241.080.00	246.030.60
BRB-350430-SN15-P-A60C	BPDB-A60C-350065	BPRB-SL-270	BPRB-CA-SN15-P	241.030.63	241.080.00	246.030.60
BRB-430510-SN15-P-A60C	BPDB-A60C-430070	BPRB-SL-270	BPRB-CA-SN15-P	241.030.63	241.080.00	246.030.60

- 可单独订购备件，按需询价
- 关于 BRB 系列桥架式刀座请参阅 P44
- 关于 BRB 系列滑块请参阅 P45

- The spare parts can be ordered separately. Please inquire on demand
- Please refer to P44 for BRB series Bridge Adaptor
- Please refer to P45 for BRB series Sliding

## BRB-SN-P 系列刀夹

BRB-SN-P Series Cartridge

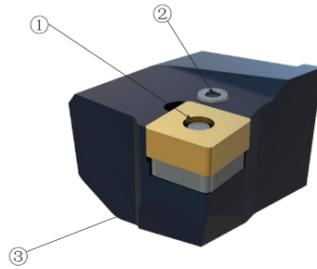

- SNMM SNMG SNMA SNGA
- 刀片仅做示意
- SNMM SNMG SNMA SNGA
- The insert is for illustration only

### > 技术参数 | Technical parameters

单位 | Unit: mm

订货号 Ordering code	刀片 Insert	夹紧方式 Coupling
BPRB-CA-SN12-P	SN..120408	P
BPRB-CA-SN15-P	SN..150612	P

产品型号 Product ID	备件   Accessory			单独订购   Purchase Separately
	① 杠杆 Lever	② 螺钉 Screw	③ 刀垫 Shim	扳手 Key
BPRB-CA-SN12-P	413.438.41	414.438.21	322.438.51	241.030.63
BPRB-CA-SN15-P	413.838.40	414.838.31	322.438.57	241.030.63

- 可单独订购备件，按需询价
- The spare parts can be ordered separately. Please inquire on demand

## BRB 系列桥架式刀座

BRB Series Bridge Adaptor



### > 技术参数 | Technical parameters

单位 | Unit: mm

订货号 Ordering code	直径范围 Fitting Range	接口 Coupling
BPDB-A40C-160050	160-215	A40C
BPDB-A40C-215050	215-270	A40C

产品型号 Product ID	备件   Accessory						单独订购   Purchase Separately	
	① 螺钉 Screw(Lock)	② 蝶形弹簧垫圈 Shim	③ 调整螺钉 Screw(Adj.)	④ 挡销 Pin(Stop)	⑤ 堵丝 Nozzle	⑥ 堵丝 Nozzle	锁紧螺钉扳手 Key(Screw)	调整螺钉扳手 Key(Adj.)
BPDB-A40C-160050	113.100.30	136.100.11	519.091.01	212.230.207	251.050.05	-	241.080.00	246.030.60
BPDB-A40C-215050	113.100.30	136.100.11	519.091.01	212.230.207	251.050.05	251.060.06	241.080.00	246.030.60

- 可单独订购备件，按需询价
- The spare parts can be ordered separately. Please inquire on demand

## BRB 系列桥架式刀座

BRB Series Bridge Adaptor

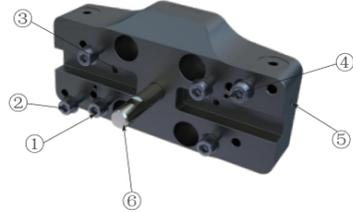

### > 技术参数 | Technical parameters

单位 | Unit: mm

订货号 Ordering code	直径范围 Fitting Range	接口 Coupling
BPDB-A60C-270060	270-350	A60C
BPDB-A60C-350065	350-430	A60C
BPDB-A60C-430070	430-510	A60C

产品型号 Product ID	备件   Accessary						单独订购   Purchase Separately
	①	②	③	④	⑤	⑥	锁紧螺钉扳手 Key(Screw)
	螺钉 Screw(Lock)	蝶形弹簧垫圈 Shim	圆柱销 Pin	堵丝 Nozzle	堵丝 Nozzle	测量销 Pin(Measuring)	
BPDB-A60C-270060	113.100.30	136.100.11	171.060.16	251.050.05	251.060.06	MP-1875	241.080.00
BPDB-A60C-350065	113.100.30	136.100.11	171.060.16	251.050.05	251.080.08	MP-1875	241.080.00
BPDB-A60C-430070	113.100.30	136.100.11	171.060.16	251.050.05	251.080.08	MP-1875	241.080.00

• 可单独订购备件，按需询价

• The spare parts can be ordered separately. Please inquire on demand

## BRB 系列滑块

BRB Series Slide

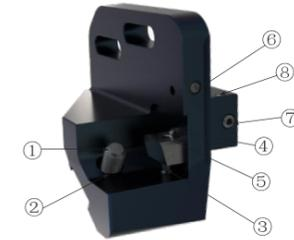

### > 技术参数 | Technical parameters

单位 | Unit: mm

订货号 Ordering code	直径范围 Fitting Range
BPRB-SL-160	160-270
BPRB-SL-270	270-510

产品型号 Product ID	备件   Accessary								单独订购   Purchase Separately	
	①	②	③	④	⑤	⑥	⑦	⑧	锁紧螺钉扳手 Key(Screw)	调整螺钉扳手 Key(Adj.)
	螺钉 Screw(Lock)	蝶形弹簧垫圈 Shim	双头螺丝 Studs	挡销 Pin(Stop)	楔块 Wedge	堵丝 Nozzle	调整螺钉 Screw(Adj.)	堵丝 Nozzle		
BPRB-SL-160	113.100.25	136.100.11	115.060.25	212.230.207	288.060.01	251.050.05	-	-	241.080.00	246.030.60
BPRB-SL-270	113.100.25	136.100.11	115.060.25	212.230.207	288.060.01	251.050.05	214.020.368	254.030.10	241.080.00	246.030.60

• 可单独订购备件，按需询价

• The spare parts can be ordered separately. Please inquire on demand

精镗刀BFI系列  
FINE-BORING BFI SERIES

01

适用于 $\Phi 20$ - $\Phi 160$ mm的孔径  
精加工

Apply to  $\Phi 20$ -  $\Phi 160$ mm aperture finishing

03

直径调节精度0.001mm

Diameter adjustment accuracy: 0.001mm

02

加工孔径公差可达IT6级

Machining aperture tolerance can reach IT6





**BFI 系列**  
BFI Series

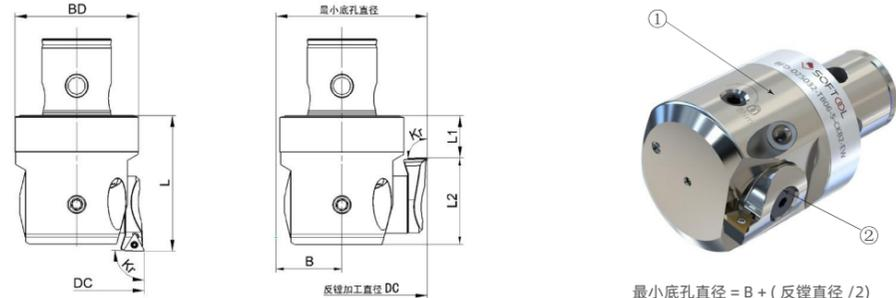

最小底孔直径 = B + (反镗直径 / 2)  
Minimum pilot hole diameter = B + (counterbore diameter / 2)

- 内冷却液供应
- TCMT TCMX TCGT TCGX TCEX TCMW
- 刀片仅做示意

- Internal coolant supply
- TCMT TCMX TCGT TCGX TCEX TCMW
- The insert is for illustration only

› 技术参数 | Technical parameters

单位 | Unit: mm

订货号 Ordering code	加长垫圈组件 <sup>2</sup> Extended washer assembly <sup>2</sup>	加长垫圈组件数量 Quantity	正镗 Positive boring				反镗 Reverse boring					主偏角 Main declination Kr	重量 m Kg	刀片 Insert	接口 Coupling
			镗削范围 Boring Range(DC)		尺寸 Dimension		镗削范围 Boring Range(DC)		尺寸 Dimension						
			Min.	Max.	L	BD	Min.	Max.	L1	L2	B				
BFI-020025-TB06-S-CKB1	-	-	20	25	32.5	18.5	-	-	10.5	19	10	92	0.07	TB.. 060102	CKB1
	BPFI-WS-025A	1	25	30			28	30							
BFI-020025-TC06-S-CKB1	-	-	20	25	32.5	18.5	-	-	10.5	19	10	92	0.07	TC.. 06T102	CKB1
	BPFI-WS-025A	2 <sup>1</sup>	30	35			30	35							
BFI-020025-TP08-S-CKB1	-	-	20	25	32.5	18.5	-	-	10.5	19	10	92	0.07	TP. 080202	CKB1
	BPFI-WS-025A	1	25	30			-	-							
BFI-025032-TB06-S-CKB2	-	-	25	32	35.5	23.5	-	-	11.5	21	12.5	92	0.12	TB.. 060102	CKB2
	BPFI-WS-035A	1	32	39			34	39							
BFI-025032-TC06-S-CKB2	-	-	25	32	35.5	23.5	-	-	11.5	21	12.5	92	0.12	TC.. 06T102	CKB2
	BPFI-WS-035A	2 <sup>1</sup>	32	39			34	39							
BFI-025032-TP08-S-CKB2	-	-	25	32	35.5	23.5	-	-	11.5	21	12.5	92	0.12	TP. 080202	CKB2
	BPFI-WS-035A	1	32	39			37	39							
BFI-025032-TP08-S-CKB2	-	-	25	32	35.5	23.5	-	-	11.5	21	12.5	92	0.12	TP. 080202	CKB2
	BPFI-WS-035A	2 <sup>1</sup>	32	39			39	46							

转下页 see next page →

**BFI 系列**  
BFI Series

› 技术参数 | Technical parameters

单位 | Unit: mm

订货号 Ordering code	加长垫圈组件 <sup>2</sup> Extended washer assembly <sup>2</sup>	加长垫圈组件数量 Quantity	正镗 Positive boring				反镗 Reverse boring					主偏角 Main declination Kr	重量 m Kg	刀片 Insert	接口 Coupling
			镗削范围 Boring Range(DC)		尺寸 Dimension		镗削范围 Boring Range(DC)		尺寸 Dimension						
			Min.	Max.	L	BD	Min.	Max.	L1	L2	B				
BFI-032042-TP08-S-CKB3	-	-	32	42	40	30	-	-	10	25	16	92	0.24	TP. 080202	CKB3
	BPFI-WS-050A	1	42	52			44	52							
	BPFI-WS-050A	2 <sup>1</sup>	52	62			52	62							
BFI-032042-TC09-S-CKB3	-	-	32	42	40	30	-	-	10	25	16	92	0.24	TC.. 090204	CKB3
	BPFI-WS-050A	1	42	52			46	52							
	BPFI-WS-050A	2 <sup>1</sup>	52	62			52	62							
BFI-032042-TP09-S-CKB3	-	-	32	42	40	30	-	-	10	25	16	92	0.24	TP. 090204	CKB3
	BPFI-WS-050A	1	42	52			46	52							
	BPFI-WS-050A	2 <sup>1</sup>	52	62			52	62							
BFI-042055-TP08-S-CKB4	-	-	42	55	47	38.5	51	55	14	29	20	92	0.43	TP. 080202	CKB4
	BPFI-WS-050B	1	52	65			52	65							
	BPFI-WS-050B	2 <sup>1</sup>	62	75			62	75							
BFI-042055-TC09-S-CKB4	-	-	42	55	47	38.5	53	55	14	29	20	92	0.43	TC.. 090204	CKB4
	BPFI-WS-050B	1	52	65			53	65							
	BPFI-WS-050B	2 <sup>1</sup>	62	75			62	75							
BFI-042055-TP09-S-CKB4	-	-	42	55	47	38.5	53	55	14	29	20	92	0.43	TP. 090204	CKB4
	BPFI-WS-050B	1	52	65			53	65							
	BPFI-WS-050B	2 <sup>1</sup>	62	75			62	75							
BFI-042055-TC1102-S-CKB4	-	-	42	55	47	38.5	-	-	14	29	20	92	0.43	TC.. 110204	CKB4
	BPFI-WS-050B	1	52	65			55	65							
	BPFI-WS-050B	2 <sup>1</sup>	62	75			62	75							
BFI-055070-TC1102-S-CKB5	-	-	55	70	57	49	65	70	19	34	25.5	92	1.1	TC.. 110204	CKB5
	BPFI-WS-060A	1	67	82			67	82							
	BPFI-WS-060A	2 <sup>1</sup>	79	94			79	94							
BFI-055070-TC1103-S-CKB5	-	-	55	70	57	49	65	70	19	34	25.5	92	1.1	TC.. 110304	CKB5
	BPFI-WS-060A	1	67	82			67	82							
	BPFI-WS-060A	2 <sup>1</sup>	79	94			79	94							

转下页 see next page →

**BFI 系列**  
BFI Series

› 技术参数 | Technical parameters

单位 | Unit: mm

订货号 Ordering code	加长垫圈组件 <sup>2</sup> Extended washer assembly <sup>2</sup>	加长垫圈组件数量 Quantity	正镗 Positive boring				反镗 Reverse boring					主偏角 Main declination Kr	重量 m Kg	刀片 Insert	接口 Coupling
			镗削范围 Boring Range(DC)		尺寸 Dimension		镗削范围 Boring Range(DC)		尺寸 Dimension						
			Min.	Max.	L	BD	Min.	Max.	L1	L2	B				
BFI-070100-TC1102-S-CKB6	-	-	70	100	71	64	80	100	22	45.2	32.5	92	1.83	TC.. 110204	CKB6
	BPFI-WS-125A	1	95	125			95	125							
	BPFI-WS-125A	2 <sup>1</sup>	120	150			120	150							
BFI-070100-TC1103-S-CKB6	-	-	70	100	71	64	80	100	22	45.2	32.5	92	1.83	TC.. 110304	CKB6
	BPFI-WS-125A	1	95	125			95	125							
	BPFI-WS-125A	2 <sup>1</sup>	120	150			120	150							
BFI-100160-TC1102-S-CKB6	-	-	100	160	71	64	106	160	22	45.2	45.5	92	2.92	TC.. 110204	CKB6
	BPFI-WS-125A	1	125	185			125	185							
	BPFI-WS-125A	2 <sup>1</sup>	150	210			150	210							
BFI-100160-TC1103-S-CKB6	-	-	100	160	71	64	106	160	22	45.2	45.5	92	2.92	TC.. 110304	CKB6
	BPFI-WS-125A	1	125	185			125	185							
	BPFI-WS-125A	2 <sup>1</sup>	150	210			150	210							
BFI-100160-TC1102-S-CKB7	-	-	100	160	87	90	109	160	38	45.2	45.5	92	4.28	TC.. 110204	CKB7
	BPFI-WS-125A	1	125	185			125	185							
	BPFI-WS-125A	2 <sup>1</sup>	150	210			150	210							
BFI-100160-TC1103-S-CKB7	-	-	100	160	87	90	109	160	38	45.2	45.5	92	4.28	TC.. 110304	CKB7
	BPFI-WS-125A	1	125	185			125	185							
	BPFI-WS-125A	2 <sup>1</sup>	150	210			150	210							

<sup>1</sup> 表示需要 2 个加长垫圈组件

<sup>2</sup> 表示加长垫圈组件需要单独订购

<sup>1</sup> Indicates that 2 extended washer assemblies are required

<sup>2</sup> Indicates that the extended washer assembly needs to be ordered separately

**BFI 系列**  
BFI Series

› 备件 | Accessory

产品型号 Product ID	①	②		
	刀座 Adaptor	刀夹 Cartridge	刀片螺钉扳手 Key(Insert)	锁紧螺钉扳手 Key(Screw)
BFI-020025-TB06-S-CKB1	BPFI-CKB1-020035	BPFI-CA-0511TB06-S	242.060.35	247.020.100
BFI-020025-TC06-S-CKB1		BPFI-CA-0511TC06-S	242.060.35	247.020.100
BFI-020025-TP08-S-CKB1		BPFI-CA-0511TP08-S	242.070.35	247.020.100
BFI-025032-TB06-S-CKB2	BPFI-CKB2-025046	BPFI-CA-0512TB06-S	242.060.35	247.020.100
BFI-025032-TC06-S-CKB2		BPFI-CA-0512TC06-S	242.060.35	247.020.100
BFI-025032-TP08-S-CKB2		BPFI-CA-0512TP08-S	242.070.35	247.020.100
BFI-032042-TP08-S-CKB3	BPFI-CKB3-032062	BPFI-CA-0715TP08-S	242.070.35	247.025.100
BFI-032042-TC09-S-CKB3		BPFI-CA-0715TC09-S	242.070.35	247.025.100
BFI-032042-TP09-S-CKB3		BPFI-CA-0715TP09-S	242.070.35	247.025.100
BFI-042055-TP08-S-CKB4	BPFI-CKB4-042075	BPFI-CA-0717TP08-S	242.070.35	247.030.100
BFI-042055-TC09-S-CKB4		BPFI-CA-0717TC09-S	242.070.35	247.030.100
BFI-042055-TP09-S-CKB4		BPFI-CA-0717TP09-S	242.070.35	247.030.100
BFI-042055-TC1102-S-CKB4		BPFI-CA-0717TC1102-S	242.070.35	247.030.100
BFI-055070-TC1102-S-CKB5	BPFI-CKB5-055094	BPFI-CA-1019TC1102-S	242.070.35	247.040.100
BFI-055070-TC1103-S-CKB5		BPFI-CA-1019TC1103-S		
BFI-070100-TC1102-S-CKB6	BPFI-CKB6-070150	BPFI-CA-1125TC1102-S	242.070.35	247.050.100
BFI-070100-TC1103-S-CKB6		BPFI-CA-1125TC1103-S		
BFI-100160-TC1102-S-CKB6	BPFI-CKB6-100210	BPFI-CA-1125TC1102-S	242.070.35	247.050.100
BFI-100160-TC1103-S-CKB6		BPFI-CA-1125TC1103-S		
BFI-100160-TC1102-S-CKB7	BPFI-CKB7-100210	BPFI-CA-1125TC1102-S	242.070.35	247.050.100
BFI-100160-TC1103-S-CKB7		BPFI-CA-1125TC1103-S		

• 可单独订购备件，按需询价

• The spare parts can be ordered separately. Please inquire on demand

**BFI 系列刀座**  
BFI Series Adaptor



› 技术参数 | Technical parameters

单位 | Unit: mm

订货号 Ordering code	直径范围 Fitting Range	接口 Coupling
BPFI-CKB1-020035	20-35	CKB1
BPFI-CKB2-025046	25-46	CKB2
BPFI-CKB3-032062	32-62	CKB3
BPFI-CKB4-042075	42-75	CKB4
BPFI-CKB5-055094	55-94	CKB5
BPFI-CKB6-070150	70-150	CKB6
BPFI-CKB6-100210	100-210	CKB6
BPFI-CKB7-100210	100-210	CKB7

产品型号 Product ID	备件   Accessory		单独订购   Purchase Separately
	① 锁紧螺钉 Screw(Lock)	② 刀夹锁紧螺钉 Screw(Cartridge)	 扳手 Key(Screw)
BPFI-CKB1-020035	119.040.05	111.035.06	247.020.100
BPFI-CKB2-025046	119.040.06	111.035.06	247.020.100
BPFI-CKB3-032062	119.050.08	114.040.08	247.025.100
BPFI-CKB4-042075	119.060.10	111.050.08	247.030.100
BPFI-CKB5-055094	119.080.12	111.080.12	247.040.100
BPFI-CKB6-070150	119.100.16	114.080.12	247.050.100
BPFI-CKB6-100210	119.100.16	114.080.12	247.050.100
BPFI-CKB7-100210	119.100.16	114.080.12	247.050.100

• 可单独订购备件，按需询价

• The spare parts can be ordered separately. Please inquire on demand

## BFI 系列刀夹

BFI Series Cartridge

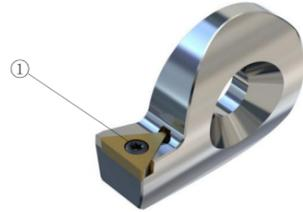

- TCMT TCMX TCGT TCGX TCEX TCMW
- 刀片仅做示意

- TCMT TCMX TCGT TCGX TCEX TCMW
- The insert is for illustration only

### 技术参数 | Technical parameters

单位 | Unit: mm

订货号 Ordering code	刀片 Insert	夹紧方式 Clamping
BPFI-CA-0511TB06-S	TB..060102	S
BPFI-CA-0511TC06-S	TC..06T102	S
BPFI-CA-0511TP08-S	TP..080202	S
BPFI-CA-0512TB06-S	TB..060102	S
BPFI-CA-0512TC06-S	TC..06T102	S
BPFI-CA-0512TP08-S	TP..080202	S
BPFI-CA-0715TP08-S	TP..080202	S
BPFI-CA-0715TC09-S	TC..090204	S
BPFI-CA-0715TP09-S	TP..090204	S
BPFI-CA-0717TP08-S	TP..080202	S
BPFI-CA-0717TC09-S	TC..090204	S
BPFI-CA-0717TP09-S	TP..090204	S
BPFI-CA-0717TC1102-S	TC..110204	S
BPFI-CA-1019TC1102-S	TC..110204	S
BPFI-CA-1019TC1103-S	TC..110304	S
BPFI-CA-1125TC1102-S	TC..110204	S
BPFI-CA-1125TC1103-S	TC..110304	S

转下页 see next page →

## BFI 系列刀夹

BFI Series Cartridge

产品型号 Product ID	备件   Accessory	
	① 刀片螺钉 Screw(Insert)	单独订购   Purchase Separately 刀片螺钉扳手 Key(Insert)
BPFI-CA-0511TB06-S	ILD2042	242.060.35
BPFI-CA-0511TC06-S	ILD2042	242.060.35
BPFI-CA-0511TP08-S	ILD2249	242.070.35
BPFI-CA-0512TB06-S	ILD2042	242.060.35
BPFI-CA-0512TC06-S	ILD2042	242.060.35
BPFI-CA-0512TP08-S	ILD2249	242.070.35
BPFI-CA-0715TP08-S	ILD2249	242.070.35
BPFI-CA-0715TC09-S	ILD 2264	242.070.35
BPFI-CA-0715TP09-S	SFS 2565	242.070.35
BPFI-CA-0717TP08-S	ILD2249	242.070.35
BPFI-CA-0717TC09-S	ILD 2264	242.070.35
BPFI-CA-0717TP09-S	SFS 2565	242.070.35
BPFI-CA-0717TC1102-S	SFS 2565	242.070.35
BPFI-CA-1019TC1102-S	SFS 2565	242.070.35
BPFI-CA-1019TC1103-S	SFS 2565	242.070.35
BPFI-CA-1125TC1102-S	SFS 2565	242.070.35
BPFI-CA-1125TC1103-S	SFS 2565	242.070.35

- 可单独订购备件，按需询价
- BFD-I 系列刀夹与 BFI 系列刀夹通用

- The spare parts can be ordered separately. Please inquire on demand
- BFD-I series cartridge and BFI series cartridge used interchangeably

## BFI 系列加长垫圈组件

BFI Series Extended Washer Assembly

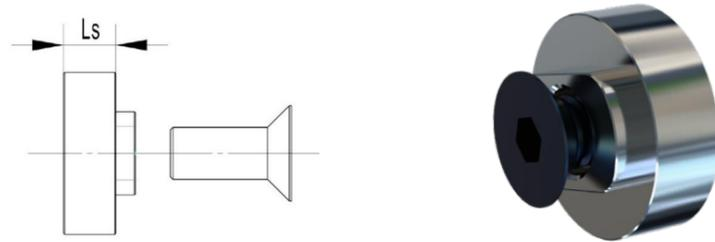

### 技术参数 | Technical parameters

单位 | Unit: mm

订货号 Ordering code	尺寸 Dimension
	Ls
BPFI-WS-025A	2.5
BPFI-WS-035A	3.5
BPFI-WS-050A	5
BPFI-WS-050B	5
BPFI-WS-060A	6
BPFI-WS-125A	12.5

备件   Accessory		单独订购   Purchase Separately	
产品型号 Product ID	锁紧螺钉 Screw(Lock)	锁紧螺钉扳手 Key(Screw)	
		BPFI-WS-025A	111.035.09
BPFI-WS-035A	111.035.09	111.035.13	247.020.100
BPFI-WS-050A	114.040.14	114.040.20	247.025.100
BPFI-WS-050B	111.050.14	111.050.19	247.030.100
BPFI-WS-060A	111.080.18	111.080.25	247.040.100
BPFI-WS-125A	114.080.25	114.080.40	247.050.100

- 可单独订购备件，按需询价
- BFD-I 系列加长垫圈组件与 BFI 系列加长垫圈组件通用

- The spare parts can be ordered separately. Please inquire on demand
- BFD-I series extended washer assembly and BFI series extended washer assembly used interchangeably

## BFI-Min 系列

BFI-Min Series

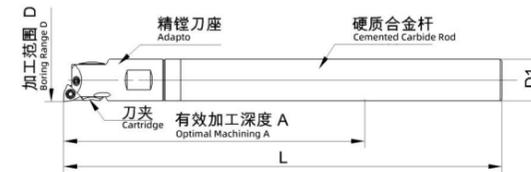

### 技术参数 | Technical parameters

单位 | Unit: mm

订货号 Ordering Code	尺寸 Dimension					刀片型号 Insert	镗刀杆型号 Boring Bar ID	刀座 Adaptor	刀夹 Cartridge	锁紧螺钉扳手 Key(Screw)	刀夹螺钉扳手 Key(Screw)
	D1	镗削范围 Boring Range	L	A	Kg						
CY12CR-BS13-90	12	13-15	131	90	0.1	WC..020102	CY12CR-M6-101-A	BS13-15	BN13	246.015.60	242.060.35
CY12CR-BS13-120			161	120	0.13		CY12CR-M6-131-A			246.015.60	242.060.35
CY14CR-BS15-110	14	15-18	151	110	0.15		CY14CR-M6-119-A	BS15-18	BN15	246.015.60	242.060.35
CY14CR-BS15-140			181	140	0.29		CY14CR-M6-149-A			246.015.60	242.060.35
CY16CR-BS18-100	16	18-22	144	100	0.28		CY16CR-M10-108-A	BS18-22		246.015.60	242.060.35
CY16CR-BS18-160			204	160	0.43		CY16CR-M10-168-A			246.015.60	242.060.35

- 注意：根据工件材料的不同，加工深度可能无法达到最大有效加工深度
- Note: Depending on the material of the workpiece, the machining depth may not reach the maximum effective machining depth

### 命名方式 | Naming And Coding Rules

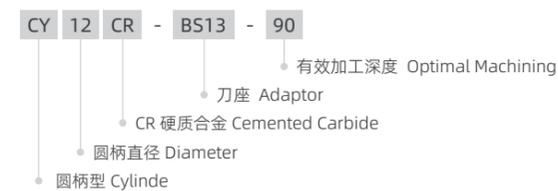

## BFI-Min 系列刀座

BFI-Min series Adaptor



### > 技术参数 | Technical parameters

单位 | Unit: mm

订货号 Ordering Code	直径范围 Fitting Range	接口 Coupling
BS13-15	13-15	M6
BS15-18	15-18	M6
BS18-22	18-22	M10

产品型号 Product ID	备件   Accessory		单独订购   Purchase Separately	
	① 锁紧螺钉 Screw(Lock)	② 刀夹锁紧螺钉 Screw(Cartridge)	 锁紧螺钉扳手 Key(Screw)	 刀夹螺钉扳手 Key(Screw)
BS13-15	251.030.03	ILD2042	246.015.60	242.060.35
BS15-18	251.030.03	ILD2042	246.015.60	242.060.35
BS18-22	251.030.04	ILD2042	246.015.60	242.060.35

• 可单独订购备件, 按需询价

• The spare parts can be ordered separately. Please inquire on demand

## BFI-Min 系列刀夹

BFI-Min series Cartridge

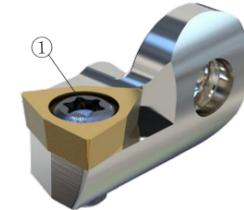

- TCMT TCMX TCGT TCGX TCEX TCMW
- 刀片仅做示意

- TCMT TCMX TCGT TCGX TCEX TCMW
- The insert is for illustration only

### > 技术参数 | Technical parameters

单位 | Unit: mm

订货号 Ordering Code	刀片 Insert	夹紧方式 Clamping
BN13	WC..020102	S
BN15	WC..020102	S

产品型号 Product ID	备件   Accessory		单独订购   Purchase Separately
	① 刀片螺钉 Screw(Insert)	 刀片螺钉扳手 Key(Insert)	 刀片螺钉扳手 Key(Insert)
BN13	ILD2042		242.060.35
BN15	ILD2042		242.060.35

• 可单独订购备件, 按需询价

• The spare parts can be ordered separately. Please inquire on demand

## BFI-Min 系列镗刀杆

BFI-Min series Boring Bar

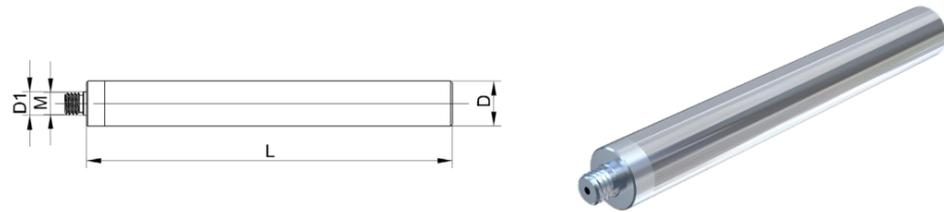

### 技术参数 | Technical parameters

单位 | Unit: mm

订货号 Ordering Code	尺寸 Dimension			重量 Weight
	D	M	L	
CY12CR-M6-101-A	12	M6	101	0.014
CY12CR-M6-131-A	12	M6	131	0.040
CY14CR-M6-119-A	14	M6	119	0.050
CY14CR-M6-149-A	14	M6	149	0.025
CY16CR-M10-108-A	16	M10	108	0.070
CY16CR-M10-168-A	16	M10	168	0.090

### 命名方式 | Naming And Coding Rules

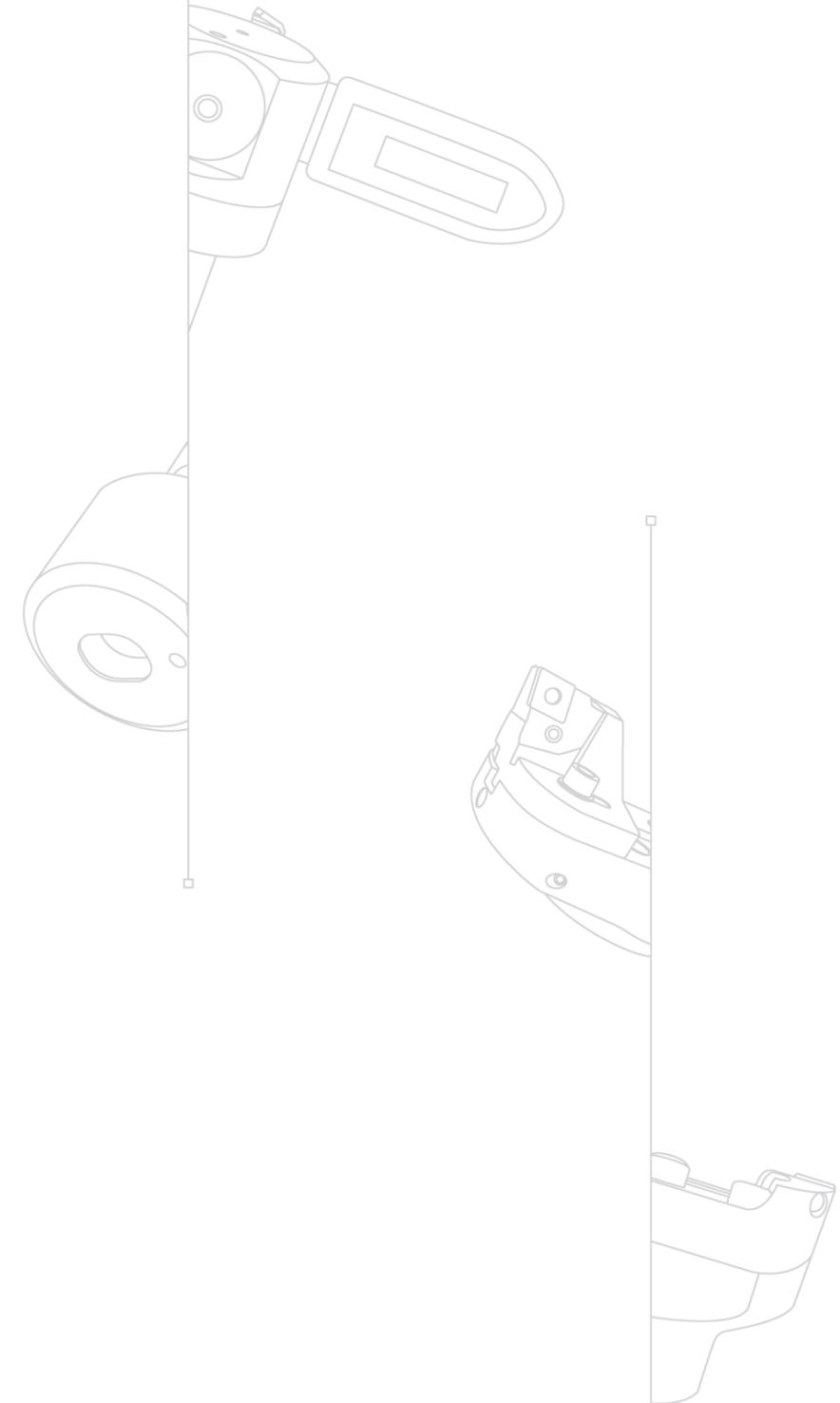
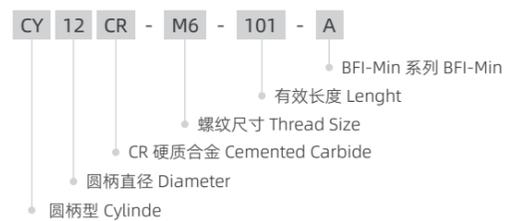



精镗刀BRB系列  
FINE-BORING BRB SERIES

01

用于 $\Phi 160$ - $\Phi 525$ mm的孔径精加工  
Apply to  $\Phi 160$ - $\Phi 525$ mm aperture finishing

02

加工孔径公差可达IT6级  
Machining aperture tolerance can reach IT6

03

航空铝桥架具有较轻的重量可减少主轴负载（与粗镗B系列通用）

Aviation aluminum bridge with less weight can reduce the spindle load (common with rough boring BRB Series)

05

可进行径向调节  
Radial adjustment is available

04

直径调节精度0.002mm  
Diameter adjustment accuracy: 0.002mm

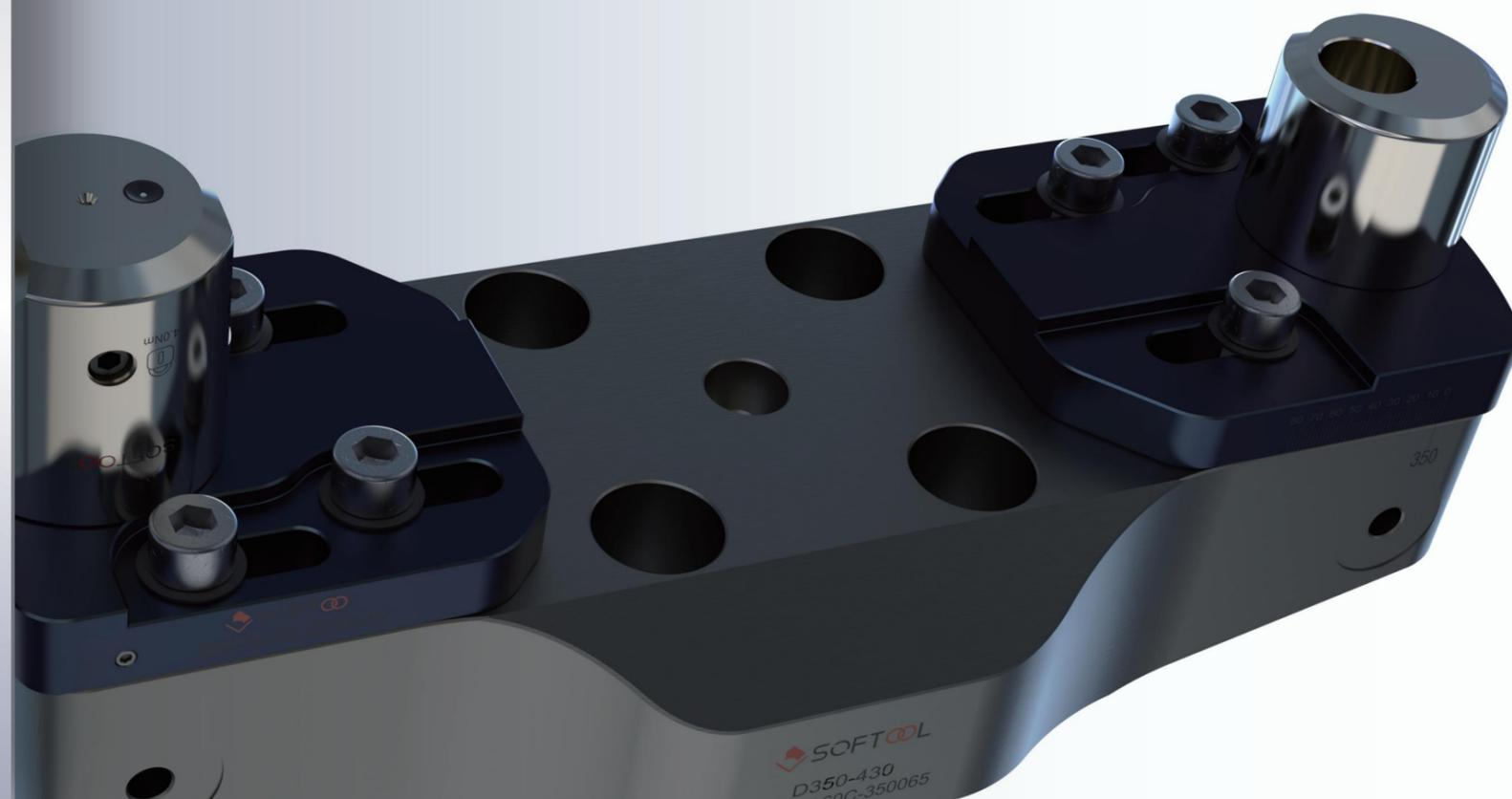

**BFB 系列**  
BFB Series

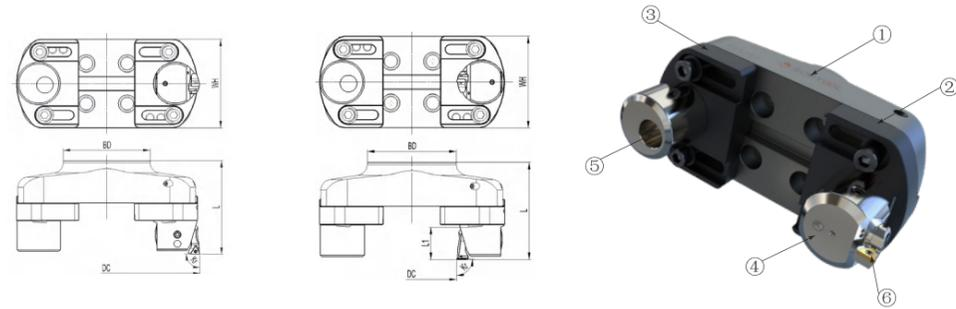

- 内冷却液供应
- TCMT TCMX TCGT TCGX TCEX TCMW
- 刀片仅做示意

- Internal coolant supply
- TCMT TCMX TCGT TCGX TCEX TCMW
- The insert is for illustration only

› 技术参数 | Technical parameters

单位 | Unit: mm

订货号 Ordering code	正镗 Positive boring			套镗 Sleeve boring			尺寸 Dimension					刀片 Insert	夹紧方式 Clamping	接口 Coupling	
	镗削范围 Boring Range(DC)			镗削范围 Boring Range(DC)			L	L1	BD	WH	Kr				G
	Min.	Max.	Adj.	Min.	Max.	Adj.									
BFB-160230-TC1102-S-A40C	160	230	70	35	105	70	118	41	100	104	92	4.5	TC.. 110204	S	A40C
BFB-160230-TC1103-S-A40C	160	230	70	35	105	70	118	41	100	104	92	4.5	TC.. 110304	S	A40C
BFB-215285-TC1102-S-A40C	215	285	70	90	160	70	118	41	100	104	92	5.0	TC.. 110204	S	A40C
BFB-215285-TC1103-S-A40C	215	285	70	90	160	70	118	41	100	104	92	5.0	TC.. 110304	S	A40C

› 备件 | Accessory

产品型号 Product ID	①	②	③	④	⑤	⑥
	桥架式刀座 Brigde Adaptor	滑块 Slide	配重滑块 Slide(CW)	精镗刀座 Adaptor	配重块 Counter-Weight	刀夹 Cartridge
BFB-160230-TC1102-S-A40C	BPDB-A40C-160050	BPFB-SL-160	BPFB-SL-160CW	BPFB-CY34-050025	BPFB-CW-5043A	BPFI-CA-1019TC1102-S
BFB-160230-TC1103-S-A40C	BPDB-A40C-160050	BPFB-SL-160	BPFB-SL-160CW	BPFB-CY34-050025	BPFB-CW-5043A	BPFI-CA-1019TC1103-S
BFB-215285-TC1102-S-A40C	BPDB-A40C-215050	BPFB-SL-160	BPFB-SL-160CW	BPFB-CY34-050025	BPFB-CW-5043A	BPFI-CA-1019TC1102-S
BFB-215285-TC1103-S-A40C	BPDB-A40C-215050	BPFB-SL-160	BPFB-SL-160CW	BPFB-CY34-050025	BPFB-CW-5043A	BPFI-CA-1019TC1103-S

产品型号 Product ID					
	刀片螺钉扳手 Key(Insert)	调整螺钉扳手 Key(Adj.)	锁紧螺钉扳手 Key(Screw)	螺钉扳手 Key(Screw)	螺钉扳手 Key(Screw)
BFB-160230-TC1102-S-A40C	242.070.35	246.030.60	247.040.100	241.050.80	241.080.00
BFB-160230-TC1103-S-A40C	242.070.35	246.030.60	247.040.100	241.050.80	241.080.00
BFB-215285-TC1102-S-A40C	242.070.35	246.030.60	247.040.100	241.050.80	241.080.00
BFB-215285-TC1103-S-A40C	242.070.35	246.030.60	247.040.100	241.050.80	241.080.00

- 可单独订购备件，按需询价

- The spare parts can be ordered separately. Please inquire on demand

**BFB 系列**  
BFB Series

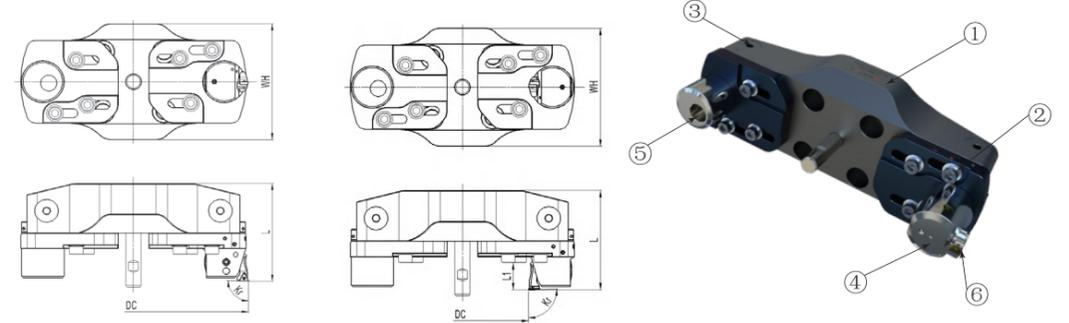

- 内冷却液供应
- TCMT TCMX TCGT TCGX TCEX TCMW
- 刀片仅做示意

- Internal coolant supply
- TCMT TCMX TCGT TCGX TCEX TCMW
- The insert is for illustration only

› 技术参数 | Technical parameters

单位 | Unit: mm

订货号 Ordering code	正镗 Positive boring			套镗 Sleeve boring			尺寸 Dimension					刀片 Insert	夹紧方式 Clamping	接口 Coupling
	镗削范围 Boring Range(DC)			镗削范围 Boring Range(DC)			L	L1	WH	Kr	G			
	Min.	Max.	Adj.	Min.	Max.	Adj.								
BFB-270365-TC1102-S-A60C	270	365	95	145	240	95	126	39	140	92	7.8	TC.. 110204	S	A60C
BFB-270365-TC1103-S-A60C	270	365	95	145	240	95	126	39	140	92	7.8	TC.. 110304	S	A60C
BFB-350445-TC1102-S-A60C	350	445	95	225	320	95	131	39	140	92	9.6	TC.. 110204	S	A60C
BFB-350445-TC1103-S-A60C	350	445	95	225	320	95	131	39	140	92	9.6	TC.. 110304	S	A60C
BFB-430525-TC1102-S-A60C	430	525	95	305	400	95	136	39	140	92	11.4	TC.. 110204	S	A60C
BFB-430525-TC1103-S-A60C	430	525	95	305	400	95	136	39	140	92	11.4	TC.. 110304	S	A60C

转下页 see next page →

## BFB 系列

BFB Series

### > 备件 | Accessory

产品型号 Product ID	①	②	③	④	⑤	⑥
	桥架式刀座 Bridge Adaptor	滑块 Slide	配重滑块 Slide(CW)	精镗刀座 Adaptor	配重块 Counter-Weight	刀夹 Cartridge
BFB-270365-TC1102-S-A60C	BPDB-A60C-270060	BPFB-SL-270	BPFB-SL-270CW	BPFB-CY34-050025	BPFB-CW-5043A	BPFI-CA-1019TC1102-S
BFB-270365-TC1103-S-A60C	BPDB-A60C-270060	BPFB-SL-270	BPFB-SL-270CW	BPFB-CY34-050025	BPFB-CW-5043A	BPFI-CA-1019TC1103-S
BFB-350445-TC1102-S-A60C	BPDB-A60C-350065	BPFB-SL-270	BPFB-SL-270CW	BPFB-CY34-050025	BPFB-CW-5043A	BPFI-CA-1019TC1102-S
BFB-350445-TC1103-S-A60C	BPDB-A60C-350065	BPFB-SL-270	BPFB-SL-270CW	BPFB-CY34-050025	BPFB-CW-5043A	BPFI-CA-1019TC1103-S
BFB-430525-TC1102-S-A60C	BPDB-A60C-430070	BPFB-SL-270	BPFB-SL-270CW	BPFB-CY34-050025	BPFB-CW-5043A	BPFI-CA-1019TC1102-S
BFB-430525-TC1103-S-A60C	BPDB-A60C-430070	BPFB-SL-270	BPFB-SL-270CW	BPFB-CY34-050025	BPFB-CW-5043A	BPFI-CA-1019TC1103-S

产品型号 Product ID					
	刀片螺钉扳手 Key(Insert)	调整螺钉扳手 Key(Adj.)	锁紧螺钉扳手 Key(Screw)	螺钉扳手 Key(Screw)	螺钉扳手 Key(Screw)
BFB-270365-TC1102-S-A60C	242.070.35	246.030.60	247.040.100	241.050.80	241.080.00
BFB-270365-TC1103-S-A60C	242.070.35	246.030.60	247.040.100	241.050.80	241.080.00
BFB-350445-TC1102-S-A60C	242.070.35	246.030.60	247.040.100	241.050.80	241.080.00
BFB-350445-TC1103-S-A60C	242.070.35	246.030.60	247.040.100	241.050.80	241.080.00
BFB-430525-TC1102-S-A60C	242.070.35	246.030.60	247.040.100	241.050.80	241.080.00
BFB-430525-TC1103-S-A60C	242.070.35	246.030.60	247.040.100	241.050.80	241.080.00

● 可单独订购备件，按需询价

● The spare parts can be ordered separately. Please inquire on demand

## BFB 系列滑块

BFB Series Slide



### > 技术参数 | Technical parameters

单位 | Unit: mm

订货号 Ordering code	直径范围 Fitting Range
BPFB-SL-160	160-285
BPFB-SL-270	270-525

产品型号 Product ID	备件   Accessory				单独订购   Purchase Separately
	① 堵丝 Nozzle	② 堵丝 Nozzle	③ 调整螺钉 Screw(Adj.)	④ 堵丝 Nozzle	 调整螺钉扳手 Key(Adj.)
BPFB-SL-160	-	251.050.05	-	-	-
BPFB-SL-270	251.040.04	251.050.05	214.020.368	254.030.10	246.030.60

● 可单独订购备件，按需询价

● BFD-B 系列滑块与 BFB 系列滑块通用

● The spare parts can be ordered separately. Please inquire on demand

● BFD-B series slide and BFB series slide used interchangeably

## BFB 系列配重滑块

BFB Series Slide(CW)



### > 技术参数 | Technical parameters

单位 | Unit: mm

订货号 Ordering code	直径范围 Fitting Range
BPFB-SL-160CW	160-285
BPFB-SL-270CW	270-525

产品型号 Product ID	备件   Accessary		单独订购   Purchase Separately
	① 调整螺钉 Screw(Adj.)	② 堵丝 Nozzle	调整螺钉扳手 Key(Adj.)
BPFB-SL-160CW	-	-	-
BPFB-SL-270CW	214.020.368	254.030.10	246.030.60

- 可单独订购备件，按需询价
- BFD-B 系列配重滑块与 BFB 系列配重滑块通用

- The spare parts can be ordered separately. Please inquire on demand
- BFD-B series slide(CW) and BFB series slide(CW) used interchangeably

## BFB 系列精镗刀座

BFB Series Adaptor

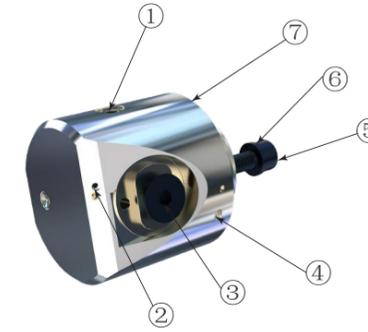

### > 技术参数 | Technical parameters

单位 | Unit: mm

订货号 Ordering code	直径范围 Fitting Range
BPFB-CY34-050025	160-525

产品型号 Product ID	备件   Accessary							单独订购   Purchase Separately	
	① 锁紧螺钉 Screw(Lock)	② 堵丝 Nozzle	③ 刀夹锁紧螺钉 Screw(Cartridge)	④ 堵丝 Nozzle	⑤ 螺钉 Screw	⑥ 垫圈 Gasket	⑦ 圆柱销 Pin	螺钉扳手 Key(Screw)	锁紧螺钉扳手 Key(Screw)
BPFB-CY34-050025	119.080.12	251.020.03	111.080.12	251.030.03	113.060.20	131.060.16	171.050.12	241.050.80	247.040.100

- 可单独订购备件，按需询价

- The spare parts can be ordered separately. Please inquire on demand

**BFB 系列配重块**  
BFB Series Counter-Weight

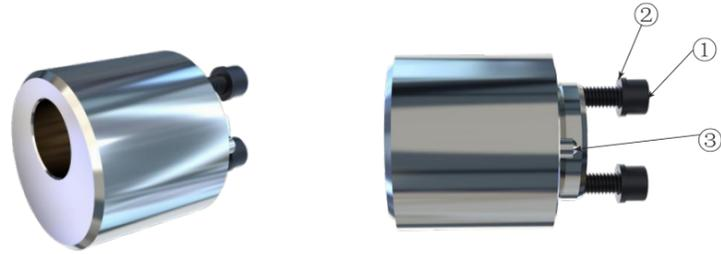

› 技术参数 | Technical parameters

单位 | Unit: mm

订货号 Ordering code	直径范围 Fitting Range
BPFB-CW-5043A	160-525

产品型号 Product ID	备件   Accessory			单独订购   Purchase Separately
	① 螺钉 Screw	② 垫圈 Gasket	③ 圆柱销 Pin	螺钉扳手 Key(Screw)
BPFB-CW-5043A	113.060.20	131.060.16	171.050.12	241.050.80

- 可单独订购备件，按需询价
- BFD-B 系列配重块与 BFB 系列配重块通用

- The spare parts can be ordered separately. Please inquire on demand
- BFD-B series counter-weight and BFB series counter-weight used interchangeably

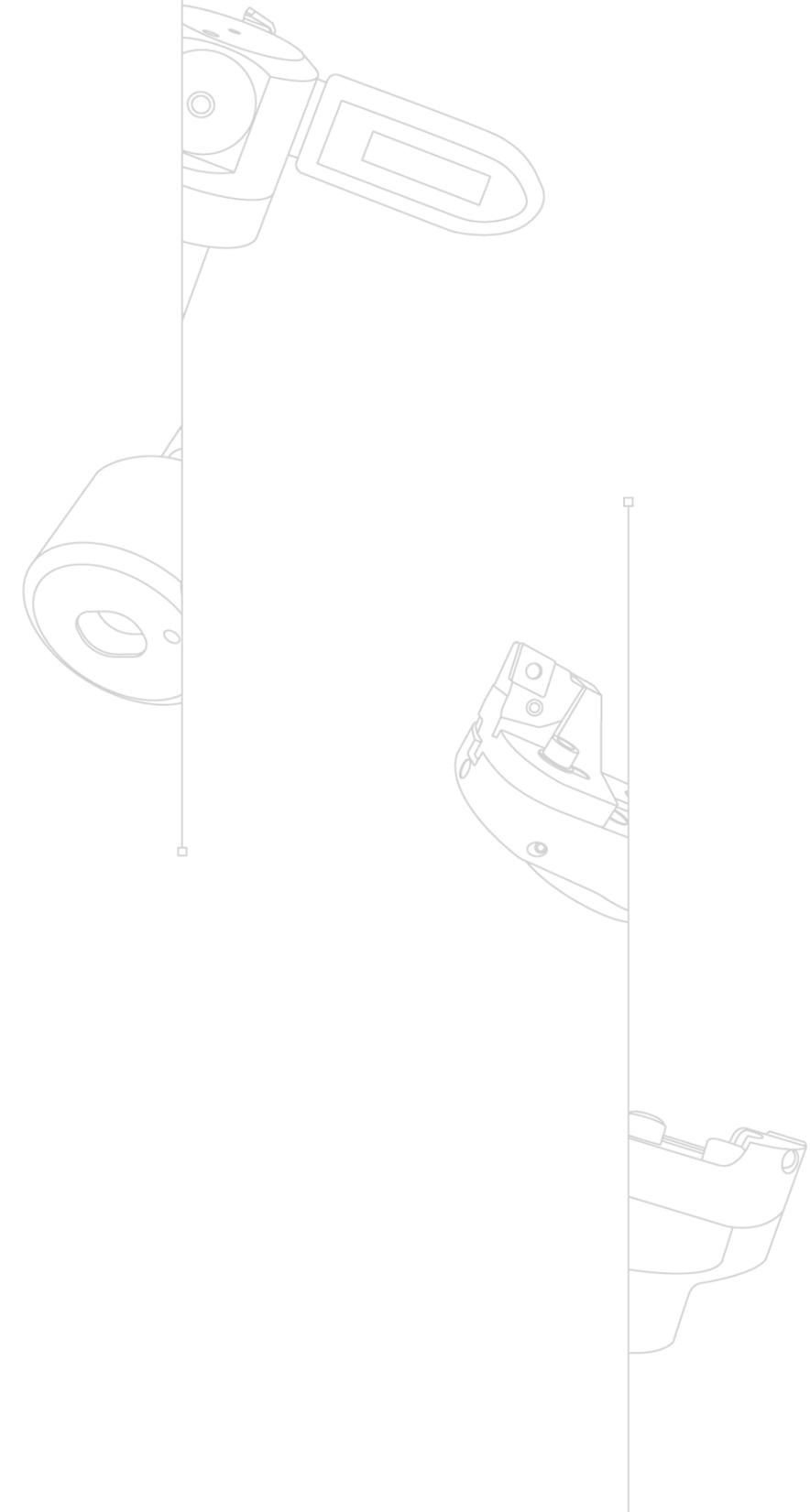

精镗刀BFH系列  
FINE-BORING BFH SERIES

01

配合镗刀杆使用可用于 $\phi 1$ - $\phi 54$ mm  
的孔径加工

Used with boring bar, it can be used for  
 $\phi 1$ - $\phi 54$ mm aperture machining

03

直径调节精度0.001mm

Diameter adjustment accuracy: 0.001mm

02

加工孔径公差可达IT6级

Machining aperture tolerance can reach IT6



**BFH 系列**  
BFH Series

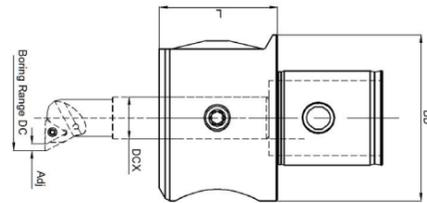

- 内冷却液供应
- TCMT TCMX TCGT TCGX TCEX TCMW
- 刀片仅做示意

- Internal coolant supply
- TCMT TCMX TCGT TCGX TCEX TCMW
- The insert is for illustration only

> 技术参数 | Technical parameters

订货号 Ordering code	尺寸 Dimension					接口 Coupling
	L	BD	DCX	Adj.	Kg	
BFH-10CKB4	28.5	39	10	2	0.25	CKB4
BFH-12CKB5	36	50	12	3.5	0.5	CKB5
BFH-16CKB6	45	63.5	16	4.5	1.1	CKB6

> 备件 | Accessory

产品型号 Product ID	①	②	
	锁紧螺钉 Screw(Lock)	锁紧螺钉 Screw(Lock)	
BFH-10CKB4	119.060.10	251.060.05	247.030.100
BFH-12CKB5	119.080.12	251.080.06	247.040.100
BFH-16CKB6	119.100.16	251.100.08	247.050.100

- 可单独订购备件，按需询价

- The spare parts can be ordered separately. Please inquire on demand

**夹套**  
Jacket

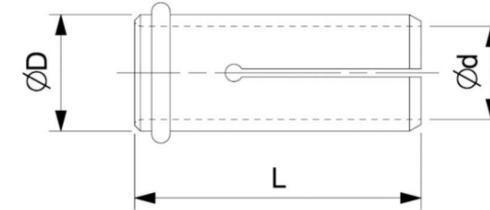

> 技术参数 | Technical parameters

单位 | Unit: mm

订货号 Ordering code	尺寸 Dimension			重量 Weight
	D	d	L	
RS1008	10	8	24.5	0.001
RS1208	12	8	30	0.001
RS1210	12	10	30	0.001
RS1608	16	8	36	0.005
RS1610	16	10	36	0.005
RS1612	16	12	36	0.005
RS1614	16	14	36	0.005

- BFD-H 夹套与 BFH 夹套通用

- BFD-H jacket and BFH jacket used interchangeably

> 命名方式 | Naming And Coding Rules



## 侧固式连接杆 Side-clamped Connection Rod

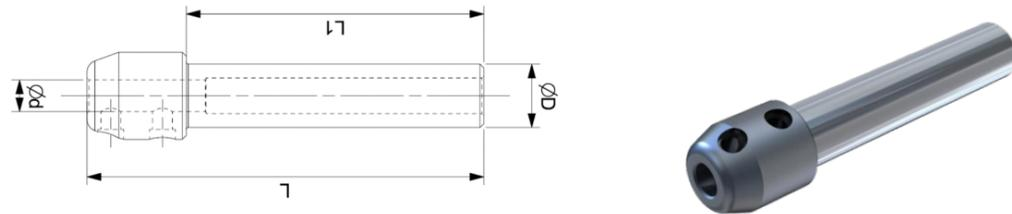

- 内冷却液供应
- Internal coolant supply

### > 技术参数 | Technical parameters

单位 | Unit: mm

订货号 Ordering code	尺寸 Dimension				重量 Weight
	D	d	L	L1	
CY16-SLN8	16	8	100	75	0.137
CY16-SLN10	16	10	100	75	0.127

### > 备件 | Accessory

产品型号 Product ID	螺钉 Key	螺钉扳手 Key(Screw)
CY16-SLN8	259.060.06	241.030.63
CY16-SLN10	259.060.06	241.030.63

- 可单独订购备件，按需询价
- The spare parts can be ordered separately. Please inquire on demand
- BFD-H 侧固式连接杆与 BFH 侧固式连接杆通用
- BFD-H side-clamped connection rod and BFH side-clamped connection rod used interchangeably

### > 命名方式 | Naming And Coding Rules



## 镗刀杆 Boring Bar

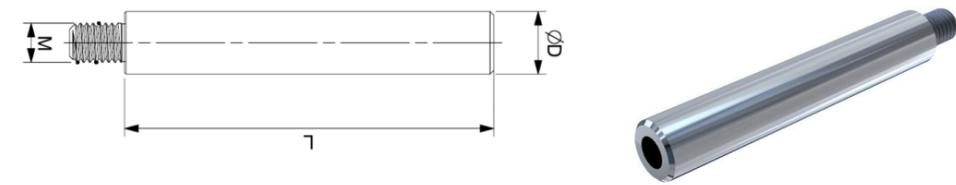

- 内冷却液供应
- Internal coolant supply

### > 技术参数 | Technical parameters

单位 | Unit: mm

订货号 Ordering code	尺寸 Dimension			适配镗刀头 Suitable for boring head	重量 Weight
	D	M	L		
CY08-M5-47	8	M5	47	BS09-TP08-M5 BS10.5-TP08-M5	0.014
CY08CR-M5-72	8	M5	72		0.040
CY08CR-M5-87	8	M5	87		0.050
CY10-M6-52	10	M6	52	BS12-TP08-M6 BS14-TP08-M6 BS16-TP08-M6	0.025
CY10CR-M6-77	10	M6	77		0.070
CY10CR-M6-97	10	M6	97		0.090
CY10-M10-58	10	M10	58	BS18-TP08-M10 BS20-TP08-M10	0.035
CY12-M6-77	12	M6	77	BS14-TP08-M6 BS16-TP08-M6	0.057
CY12CR-M6-107	12	M6	107		0.160
CY12CR-M6-137	12	M6	137		0.210
CY12-M10-72	12	M10	72	BS18-TP08-M10 BS20-TP08-M10 BS22-TP08-M10 BS24-TP08-M10 BS26-TP08-M10 BS28-TP08-M10 BS30-TP08-M10	0.065
CY12CR-M10-112	12	M10	112		0.200
CY12CR-M10-142	12	M10	142		0.240

转下页 see next page →



## 镗刀杆 Boring Bar

### > 备件 | Accessory

订货号 Ordering code	尺寸 Dimension			适配镗刀头 Suitable for boring head	重量 Weight
	D	M	L		
CY14-M6-87	14	M6	87	BS16-TP08-M6	0.980
CY14CR-M6-117	14	M6	117		0.290
CY14CR-M6-147	14	M6	147		0.312
CY16-M10-88	16	M10	88	BS18-TP08-M10 BS20-TP08-M10 BS22-TP08-M10 BS24-TP08-M10 BS26-TP08-M10 BS28-TP08-M10 BS30-TP08-M10 BS32-TP08-M10 BS34-TP08-M10 BS36-TP08-M10 BS38-TP08-M10 BS40-TP08-M10 BS42-TP08-M10 BS46-TP08-M10	0.130
CY16CR-M10-108	16	M10	108		0.300
CY16CR-M10-168	16	M10	168		0.460

- 注：型号中带“CR”的是硬质合金镗杆
- BFD-H 镗刀杆与 BFH 镗刀杆通用

- Note: The models with "CR" are cemented carbide boring bars
- BFD-H boring bar and BFH boring bar used interchangeably

### > 命名方式 | Naming And Coding Rules

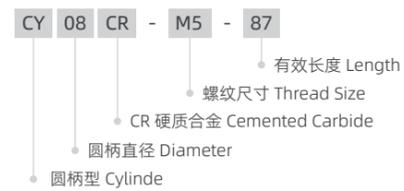

## 镗刀头 Boring Head

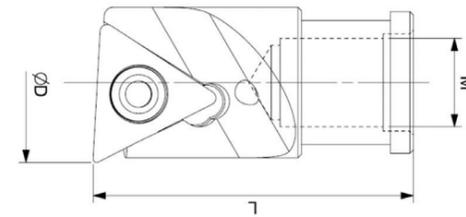

- 内冷却液供应

- Internal coolant supply

### > 技术参数 | Technical parameters

单位 | Unit: mm

订货号 Ordering code	尺寸 Dimension			刀片 Insert	重量 Weight
	M	L	D		
BS09-TP08-M5	M5	18	9-11	TP.080202	0.004
BS10.5-TP08-M5	M5	18	10.5-12.5	TP.080202	0.005
BS12-TP08-M6	M6	23	12-14	TP.080202	0.007
BS14-TP08-M6	M6	23	14-16	TP.080202	0.009
BS16-TP08-M6	M6	23	16-18	TP.080202	0.012
BS18-TP08-M10	M10	27	18-20	TP.080202	0.017
BS20-TP08-M10	M10	27	20-22	TP.080202	0.024
BS22-TP08-M10	M10	27	22-24	TP.080202	0.025
BS24-TP08-M10	M10	27	24-26	TP.080202	0.026
BS26-TP08-M10	M10	27	26-28	TP.080202	0.028
BS28-TP08-M10	M10	27	28-30	TP.080202	0.029
BS30-TP08-M10	M10	27	30-32	TP.080202	0.029
BS32-TP08-M10	M10	27	32-34	TP.080202	0.030
BS34-TP08-M10	M10	27	34-36	TP.080202	0.030
BS36-TP08-M10	M10	27	36-38	TP.080202	0.031
BS38-TP08-M10	M10	27	38-40	TP.080202	0.031
BS40-TP08-M10	M10	27	40-42	TP.080202	0.031
BS42-TP08-M10	M10	27	42-46	TP.080202	0.033
BS46-TP08-M10	M10	27	46-50	TP.080202	0.034

转下页 see next page →

## 镗刀头 Boring Head

### > 备件 | Accessory

刀片 Insert	刀片螺钉 Screw(Insert)	刀片螺钉扳手 Key(Insert)
TP.080202	ILD2249	242.070.35

- 可单独订购备件，按需询价
- BFD-H 镗刀头与 BFH 镗刀头通用
- The spare parts can be ordered separately. Please inquire on demand
- BFD-H boring head and BFH boring head used interchangeably

### > 命名方式 | Naming And Coding Rules

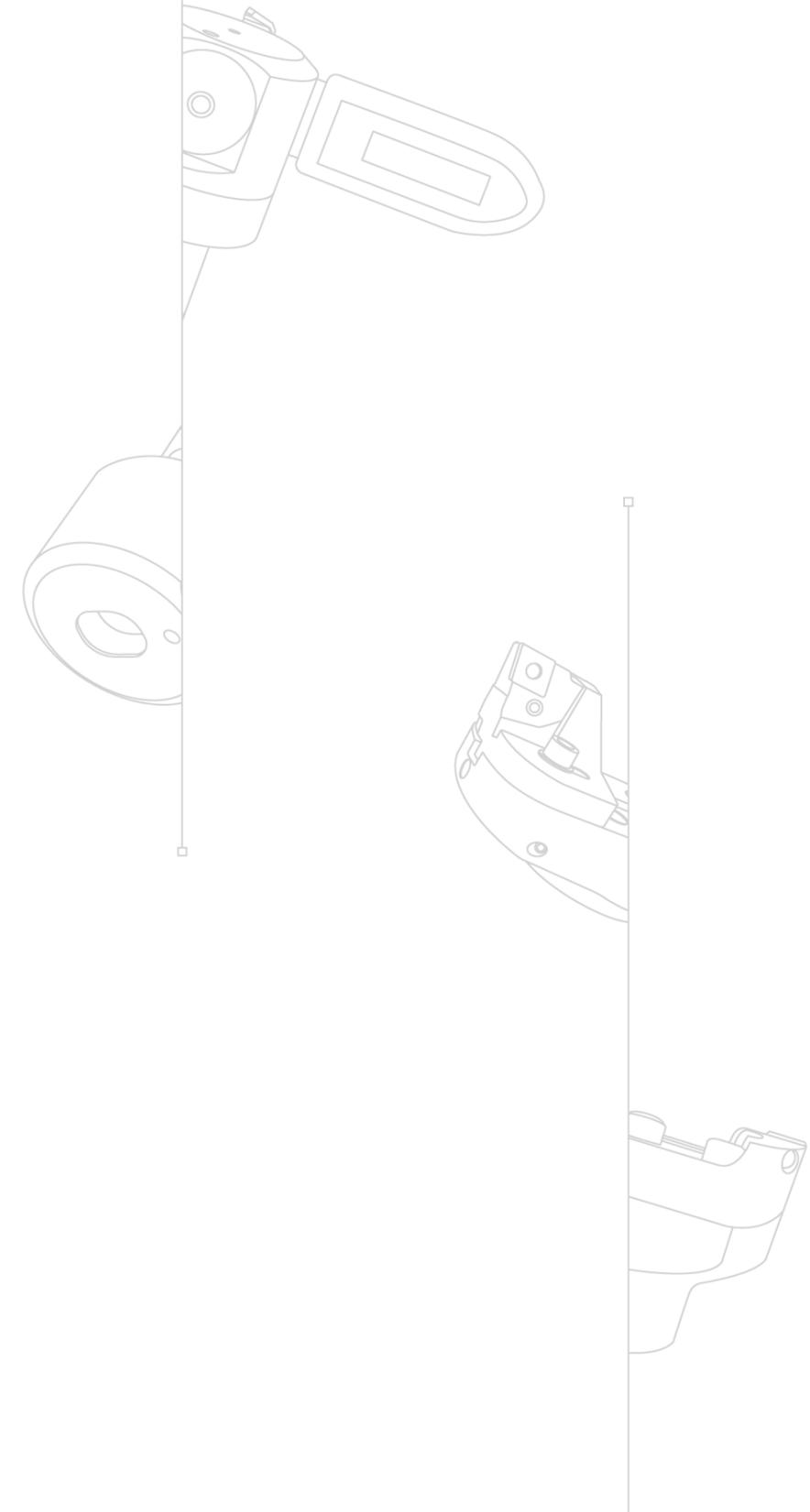

# 数显精镗刀 BFD-1 系列

DIGITAL DISPLAY FINE-BORING BFD-1 SERIES

## 01

具备机械式精镗刀的所有优点

Possesses all the advantages of a mechanical precision boring tool

## 03

刀具直径调节精度0.001mm

The tool diameter adjustment precision is 0.001mm

## 05

可以检测出锁紧螺钉引起的刀尖位移变化量，保证调节精度

It can detect the changes in tool tip displacement caused by the tightening of the locking screws, ensuring the precision of adjustment

## 02

刀具调节可视化，方便且直观

The tool adjustment is visualized, making it convenient and intuitive

## 04

显示精度为刀尖实际位移，避免螺纹副引起的误差

Display the precision as the actual displacement of the tool tip to avoid errors caused by the engagement of threads



**BFD-I 系列**  
BFD-I Series

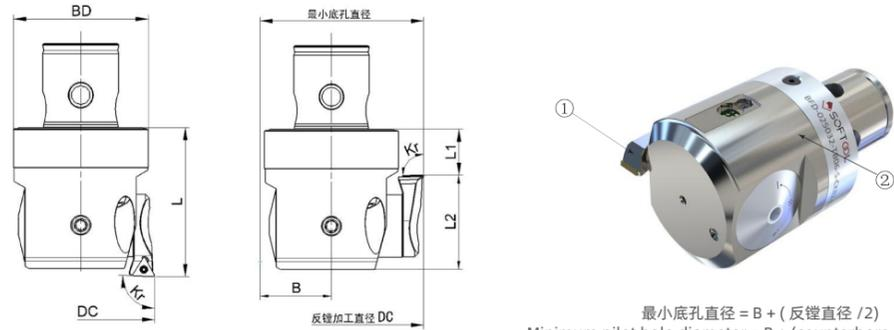

最小底孔直径 = B + (反镗直径 / 2)  
Minimum pilot hole diameter = B + (counterbore diameter / 2)

- 内冷却液供应
- TCMT TCMX TCGT TCGX TCEX TCMW
- 刀片仅做示意

- Internal coolant supply
- TCMT TCMX TCGT TCGX TCEX TCMW
- The insert is for illustration only

› 技术参数 | Technical parameters

单位 | Unit: mm

订货号 Ordering code	加长垫圈组件 <sup>2</sup> Extended washer assembly <sup>2</sup>	加长垫圈组件数量 Quantity	正镗 Positive boring				反镗 Reverse boring					主偏角 Main declination Kr	重量 m Kg	刀片 Insert	接口 Coupling
			镗削范围 Boring Range(DC)		尺寸 Dimension		镗削范围 Boring Range(DC)		尺寸 Dimension						
			Min.	Max.	L	BD	Min.	Max.	L1	L2	B				
BFD-025032-TB06-S-CKB2-EW	-	-	25	32	45.5	23.5	-	-	21.5	21	12.5	92	0.13	TB.. 060102	CKB2
	BPFI-WS-035A	1	32	39			34	39							
BFD-025032-TC06-S-CKB2-EW	-	-	25	32	45.5	23.5	-	-	21.5	21	12.5	92	0.13	TC.. 06T102	CKB2
	BPFI-WS-035A	1	32	39			34	39							
BFD-025032-TP08-S-CKB2-EW	-	-	25	32	45.5	23.5	-	-	21.5	21	12.5	92	0.13	TP. 080202	CKB2
	BPFI-WS-035A	1	32	39			37	39							
BFD-032042-TP08-S-CKB3-EW	-	-	32	42	48	30	-	-	18	25	16	92	0.25	TP. 080202	CKB3
	BPFI-WS-050A	1	42	52			44	52							
BFD-032042-TC09-S-CKB3-EW	-	-	32	42	48	30	-	-	18	25	16	92	0.25	TC.. 090204	CKB3
	BPFI-WS-050A	1	42	52			46	52							
BFD-032042-TP09-S-CKB3-EW	-	-	32	42	48	30	-	-	18	25	16	92	0.25	TP. 090204	CKB3
	BPFI-WS-050A	1	42	52			46	52							

转下页 see next page →

**BFD-I 系列**  
BFD-I Series

› 技术参数 | Technical parameters

单位 | Unit: mm

订货号 Ordering code	加长垫圈组件 <sup>2</sup> Extended washer assembly <sup>2</sup>	加长垫圈组件数量 Quantity	正镗 Positive boring				反镗 Reverse boring					主偏角 Main declination Kr	重量 m Kg	刀片 Insert	接口 Coupling
			镗削范围 Boring Range(DC)		尺寸 Dimension		镗削范围 Boring Range(DC)		尺寸 Dimension						
			Min.	Max.	L	BD	Min.	Max.	L1	L2	B				
BFD-042055-TP08-S-CKB4-EW	-	-	42	55	52	38.5	51	55	19	29	20	92	0.56	TP. 080202	CKB4
	BPFI-WS-050B	1	52	65			52	65							
	BPFI-WS-050B	2 <sup>1</sup>	62	75			62	75							
BFD-042055-TC09-S-CKB4-EW	-	-	42	55	52	38.5	53	55	19	29	20	92	0.56	TC.. 090204	CKB4
	BPFI-WS-050B	1	52	65			53	65							
	BPFI-WS-050B	2 <sup>1</sup>	62	75			62	75							
BFD-042055-TP09-S-CKB4-EW	-	-	42	55	52	38.5	53	55	19	29	20	92	0.56	TP. 090204	CKB4
	BPFI-WS-050B	1	52	65			53	65							
	BPFI-WS-050B	2 <sup>1</sup>	62	75			62	75							
BFD-042055-TC1102-S-CKB4-EW	-	-	42	55	52	38.5	-	-	19	29	20	92	0.56	TC.. 110204	CKB4
	BPFI-WS-050B	1	52	65			55	65							
	BPFI-WS-050B	2 <sup>1</sup>	62	75			62	75							
BFD-055070-TC1102-S-CKB5-EW	-	-	55	70	57	49	65	70	19	34	25.5	92	1.1	TC.. 110204	CKB5
	BPFI-WS-060A	1	67	82			67	82							
	BPFI-WS-060A	2 <sup>1</sup>	79	94			79	94							
BFD-055070-TC1103-S-CKB5-EW	-	-	55	70	57	49	65	70	19	34	25.5	92	1.1	TC.. 110304	CKB5
	BPFI-WS-060A	1	67	82			67	82							
	BPFI-WS-060A	2 <sup>1</sup>	79	94			79	94							
BFD-070100-TC1102-S-CKB6-EW	-	-	70	100	71	64	80	100	22	45.2	32.5	92	1.83	TC.. 110204	CKB6
	BPFI-WS-125A	1	95	125			95	125							
	BPFI-WS-125A	2 <sup>1</sup>	120	150			120	150							
BFD-070100-TC1103-S-CKB6-EW	-	-	70	100	71	64	80	100	22	45.2	32.5	92	1.83	TC.. 110304	CKB6
	BPFI-WS-125A	1	95	125			95	125							
	BPFI-WS-125A	2 <sup>1</sup>	120	150			120	150							

转下页 see next page →

**BFD-I 系列**  
BFD-I Series

› 技术参数 | Technical parameters

单位 | Unit: mm

订货号 Ordering code	加长垫圈组件 <sup>2</sup> Extended washer assembly <sup>2</sup>	加长垫圈组件数量 Quantity	正镗 Positive boring				反镗 Reverse boring					主偏角 Main declination Kr	重量 m Kg	刀片 Insert	接口 Coupling
			镗削范围 Boring Range(DC)		尺寸 Dimension		镗削范围 Boring Range(DC)		尺寸 Dimension						
			Min.	Max.	L	BD	Min.	Max.	L1	L2	B				
BFD-100160-TC1102-S-CKB6-EW	-	-	100	160	71	64	106	160	22	45.2	45.5	92	2.92	TC.. 110204	CKB6
	BPFI-WS-125A	1	125	185			125	185							
	BPFI-WS-125A	2 <sup>1</sup>	150	210			150	210							
BFD-100160-TC1103-S-CKB6-EW	-	-	100	160	71	64	106	160	22	45.2	45.5	92	2.92	TC.. 110304	CKB6
	BPFI-WS-125A	1	125	185			125	185							
	BPFI-WS-125A	2 <sup>1</sup>	150	210			150	210							
BFD-100160-TC1102-S-CKB7-EW	-	-	100	160	87	90	109	160	38	45.2	45.5	92	4.28	TC.. 110204	CKB7
	BPFI-WS-125A	1	125	185			125	185							
	BPFI-WS-125A	2 <sup>1</sup>	150	210			150	210							
BFD-100160-TC1103-S-CKB7-EW	-	-	100	160	87	90	109	160	38	45.2	45.5	92	4.28	TC.. 110304	CKB7
	BPFI-WS-125A	1	125	185			125	185							
	BPFI-WS-125A	2 <sup>1</sup>	150	210			150	210							

<sup>1</sup> 表示需要 2 个加长垫圈组件

<sup>2</sup> 表示加长垫圈组件需要单独订购

<sup>1</sup> Indicates that 2 extended washer assemblies are required

<sup>2</sup> Indicates that the extended washer assembly needs to be ordered separately

## BFD-I 系列

BFD-I Series

### > 备件 | Accessory

产品型号 Product ID	①	②		
	刀座 Adaptor	刀夹 Cartridge	刀片螺钉扳手 Key(Insert)	锁紧螺钉扳手 Key(Screw)
BFD-025032-TB06-S-CKB2-EW	BPF-D-CKB2-025046-EW	BPFI-CA-0512TB06-S	242.060.35	247.020.100
BFD-025032-TC06-S-CKB2-EW		BPFI-CA-0512TC06-S	242.060.35	247.020.100
BFD-025032-TP08-S-CKB2-EW		BPFI-CA-0512TP08-S	242.070.35	247.020.100
BFD-032042-TP08-S-CKB3-EW	BPF-D-CKB3-032062-EW	BPFI-CA-0715TP08-S	242.070.35	247.025.100
BFD-032042-TC09-S-CKB3-EW		BPFI-CA-0715TC09-S	242.070.35	247.025.100
BFD-032042-TP09-S-CKB3-EW		BPFI-CA-0715TP09-S	242.070.35	247.025.100
BFD-042055-TP08-S-CKB4-EW	BPF-D-CKB4-042075-EW	BPFI-CA-0717TP08-S	242.070.35	247.030.100
BFD-042055-TC09-S-CKB4-EW		BPFI-CA-0717TC09-S	242.070.35	247.030.100
BFD-042055-TP09-S-CKB4-EW		BPFI-CA-0717TP09-S	242.070.35	247.030.100
BFD-042055-TC1102-S-CKB4-EW		BPFI-CA-0717TC1102-S	242.070.35	247.030.100
BFD-055070-TC1102-S-CKB5-EW	BPF-D-CKB5-055094-EW	BPFI-CA-1019TC1102-S	242.070.35	247.040.100
BFD-055070-TC1103-S-CKB5-EW		BPFI-CA-1019TC1103-S		
BFD-070100-TC1102-S-CKB6-EW	BPF-D-CKB6-070150-EW	BPFI-CA-1125TC1102-S	242.070.35	247.050.100
BFD-070100-TC1103-S-CKB6-EW		BPFI-CA-1125TC1103-S		
BFD-100160-TC1102-S-CKB6-EW	BPF-D-CKB6-100210-EW	BPFI-CA-1125TC1102-S	242.070.35	247.050.100
BFD-100160-TC1103-S-CKB6-EW		BPFI-CA-1125TC1103-S		
BFD-100160-TC1102-S-CKB7-EW	BPF-D-CKB7-100210-EW	BPFI-CA-1125TC1102-S	242.070.35	247.050.100
BFD-100160-TC1103-S-CKB7-EW		BPFI-CA-1125TC1103-S		

• 可单独订购备件，按需询价

• The spare parts can be ordered separately. Please inquire on demand

## BFD-I 系列刀座

BFD-I Series Adaptor



### > 技术参数 | Technical parameters

单位 | Unit: mm

订货号 Ordering code	直径范围 Fitting Range	接口 Coupling
BPF-D-CKB2-025046-EW	25-46	CKB2
BPF-D-CKB3-032062-EW	32-62	CKB3
BPF-D-CKB4-042075-EW	42-75	CKB4
BPF-D-CKB5-055094-EW	55-94	CKB5
BPF-D-CKB6-070150-EW	70-150	CKB6
BPF-D-CKB6-100210-EW	100-210	CKB6
BPF-D-CKB7-100210-EW	100-210	CKB7

产品型号 Product ID	备件   Accessory		单独订购   Purchase Separately
	① 锁紧螺钉 Screw(Lock)	② 刀夹锁紧螺钉 Screw(Cartridge)	 扳手 Key(Screw)
BPF-D-CKB2-025046-EW	119.040.06	111.035.06	247.020.100
BPF-D-CKB3-032062-EW	119.050.08	114.040.08	247.025.100
BPF-D-CKB4-042075-EW	119.060.10	111.050.08	247.030.100
BPF-D-CKB5-055094-EW	119.080.12	111.080.12	247.040.100
BPF-D-CKB6-070150-EW	119.100.16	114.080.12	247.050.100
BPF-D-CKB6-100210-EW	119.100.16	114.080.12	247.050.100
BPF-D-CKB7-100210-EW	119.100.16	114.080.12	247.050.100

• 可单独订购备件，按需询价

• The spare parts can be ordered separately. Please inquire on demand

## BFD-I 系列刀夹

BFD-I Series Cartridge

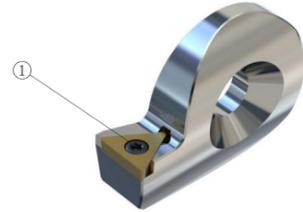

- TCMT TCMX TCGT TCGX TCEX TCMW
- 刀片仅做示意

- TCMT TCMX TCGT TCGX TCEX TCMW
- The insert is for illustration only

### 技术参数 | Technical parameters

单位 | Unit: mm

订货号 Ordering code	刀片 Insert	夹紧方式 Clamping
BPFI-CA-0512TB06-S	TB..060102	S
BPFI-CA-0512TC06-S	TC..06T102	S
BPFI-CA-0512TP08-S	TP..080202	S
BPFI-CA-0715TP08-S	TP..080202	S
BPFI-CA-0715TC09-S	TC..090204	S
BPFI-CA-0715TP09-S	TP..090204	S
BPFI-CA-0717TP08-S	TP..080202	S
BPFI-CA-0717TC09-S	TC..090204	S
BPFI-CA-0717TP09-S	TP..090204	S
BPFI-CA-0717TC1102-S	TC..110204	S
BPFI-CA-1019TC1102-S	TC..110204	S
BPFI-CA-1019TC1103-S	TC..110304	S
BPFI-CA-1125TC1102-S	TC..110204	S
BPFI-CA-1125TC1103-S	TC..110304	S
BPFI-CA-1019TC1103-S	TC..110304	S
BPFI-CA-1125TC1102-S	TC..110204	S
BPFI-CA-1125TC1103-S	TC..110304	S

转下页 see next page →

## BFD-I 系列刀夹

BFD-I Series Cartridge

产品型号 Product ID	备件   Accessory	
	① 刀片螺钉 Screw(Insert)	单独订购   Purchase Separately 刀片螺钉扳手 Key(Insert)
BPFI-CA-0511TB06-S	ILD2042	242.060.35
BPFI-CA-0511TC06-S	ILD2042	242.060.35
BPFI-CA-0511TP08-S	ILD2249	242.070.35
BPFI-CA-0512TB06-S	ILD2042	242.060.35
BPFI-CA-0512TC06-S	ILD2042	242.060.35
BPFI-CA-0512TP08-S	ILD2249	242.070.35
BPFI-CA-0715TP08-S	ILD2249	242.070.35
BPFI-CA-0715TC09-S	ILD 2264	242.070.35
BPFI-CA-0715TP09-S	SFS 2565	242.070.35
BPFI-CA-0717TP08-S	ILD2249	242.070.35
BPFI-CA-0717TC09-S	ILD 2264	242.070.35
BPFI-CA-0717TP09-S	SFS 2565	242.070.35
BPFI-CA-0717TC1102-S	SFS 2565	242.070.35
BPFI-CA-1019TC1102-S	SFS 2565	242.070.35
BPFI-CA-1019TC1103-S	SFS 2565	242.070.35
BPFI-CA-1125TC1102-S	SFS 2565	242.070.35
BPFI-CA-1125TC1103-S	SFS 2565	242.070.35

- 可单独订购备件，按需询价
- BFD-I 系列刀夹与 BFI 系列刀夹通用

- The spare parts can be ordered separately. Please inquire on demand
- BFD-I series cartridge and BFI series cartridge used interchangeably



## BFD-I 系列加长垫圈组件

BFD-I Series Extended Washer Assembly

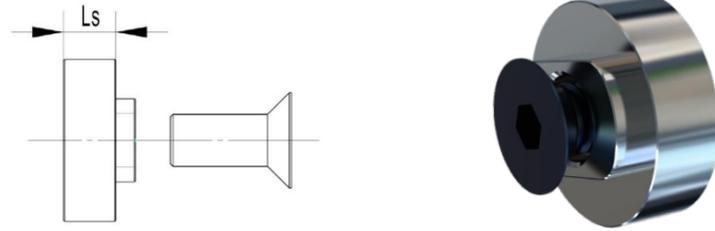

### 技术参数 | Technical parameters

单位 | Unit: mm

订货号 Ordering code	尺寸 Dimension
	Ls
BPFI-WS-035A	3.5
BPFI-WS-050A	5
BPFI-WS-050B	5
BPFI-WS-060A	6
BPFI-WS-125A	12.5

备件   Accessory			单独订购   Purchase Separately
产品型号 Product ID	锁紧螺钉 Screw(Lock)		锁紧螺钉扳手 Key(Screw)
	BPFI-WS-035A	111.035.09	111.035.13
BPFI-WS-050A	114.040.14	114.040.20	247.025.100
BPFI-WS-050B	111.050.14	111.050.19	247.030.100
BPFI-WS-060A	111.080.18	111.080.25	247.040.100
BPFI-WS-125A	114.080.25	114.080.40	247.050.100

- 可单独订购备件，按需询价
- The spare parts can be ordered separately. Please inquire on demand
- BFD-I 系列加长垫圈组件与 BFI 系列加长垫圈组件通用
- BFD-I series extended washer assembly and BFI series extended washer assembly used interchangeably

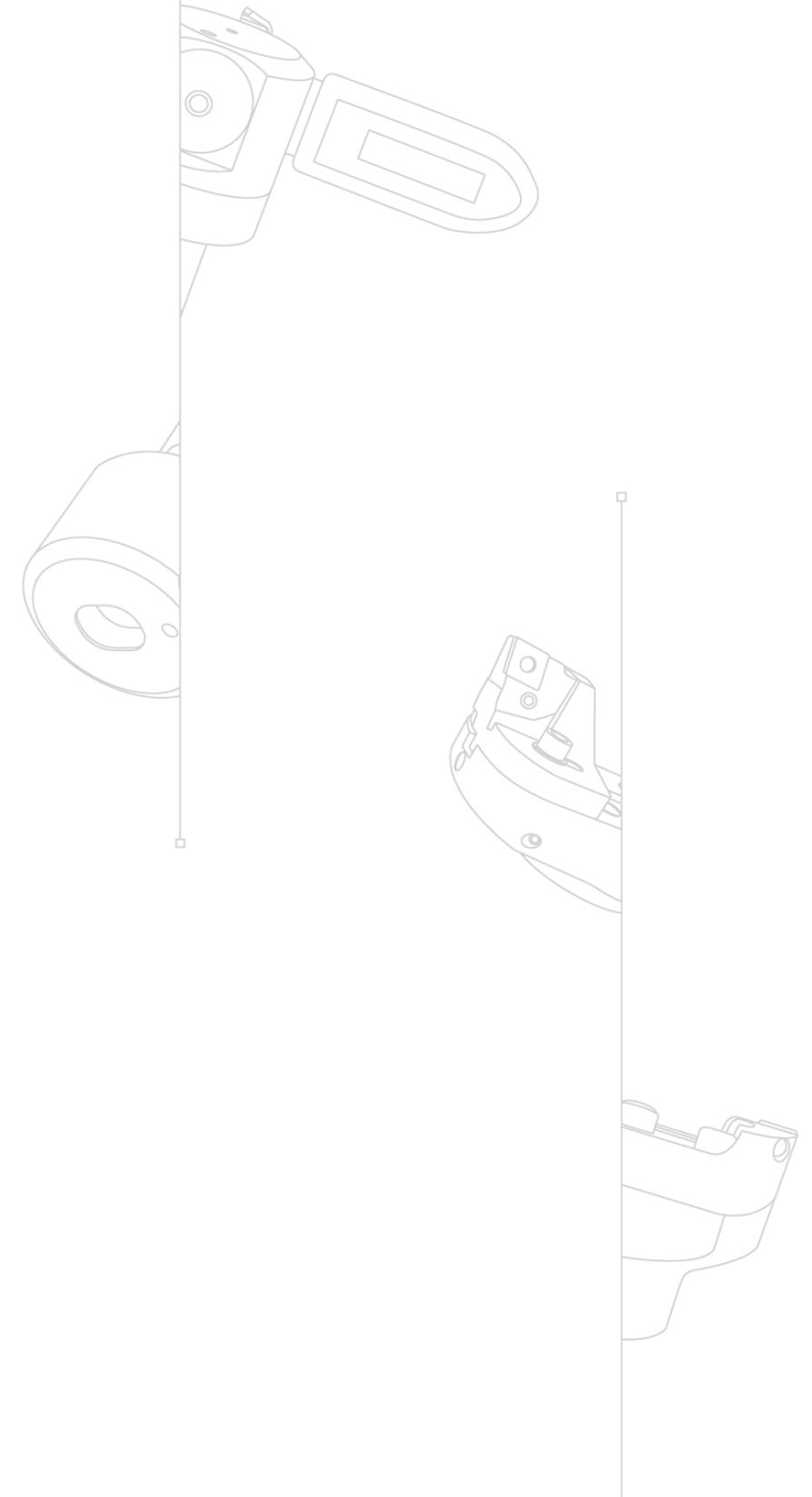

# 数显精镗刀 BFD-B 系列

DIGITAL DISPLAY FINE-BORING BFD-B SERIES

## 01

具备机械式精镗刀的所有优点

Possesses all the advantages of a mechanical precision boring tool

## 03

刀具直径调节精度0.001mm

The tool diameter adjustment precision is 0.001mm

## 05

可以检测出锁紧螺钉引起的刀尖位移变化量，保证调节精度

It can detect the changes in tool tip displacement caused by the tightening of the locking screws, ensuring the precision of adjustment

## 02

刀具调节可视化，方便且直观

The tool adjustment is visualized, making it convenient and intuitive

## 04

显示精度为刀尖实际位移，避免螺纹副引起的误差

Display the precision as the actual displacement of the tool tip to avoid errors caused by the engagement of threads



## BFD-B 系列

BFD-B Series

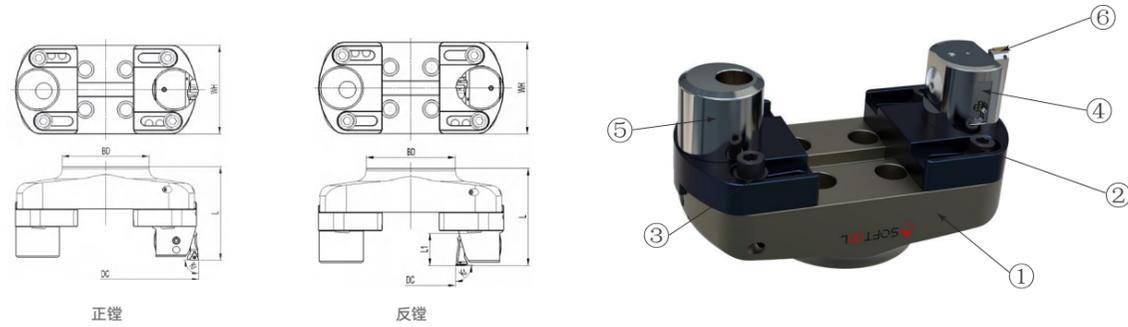

- 内冷却液供应
- TCMT TCMX TCGT TCGX TCEX TCMW
- 刀片仅做示意

- Internal coolant supply
- TCMT TCMX TCGT TCGX TCEX TCMW
- The insert is for illustration only

### 技术参数 | Technical parameters

单位 | Unit: mm

订货号 Ordering code	正镗 Positive boring			套镗 Sleeve boring			尺寸 Dimension						刀片 Insert	夹紧方式 Clamping	接口 Coupling
	镗削范围 Boring Range(DC)			镗削范围 Boring Range(DC)			L	L1	BD	WH	Kr	KG			
	Min.	Max.	Adj.	Min.	Max.	Adj.									
BFD-160230-TC1102-S-A40C-EW	160	230	70	35	105	70	118	41	100	104	92	4.5	TC.. 110204	S	A40C
BFD-160230-TC1103-S-A40C-EW	160	230	70	35	105	70	118	41	100	104	92	4.5	TC.. 110304	S	A40C
BFD-215285-TC1102-S-A40C-EW	215	285	70	90	160	70	118	41	100	104	92	5	TC.. 110204	S	A40C
BFD-215285-TC1103-S-A40C-EW	215	285	70	90	160	70	118	41	100	104	92	5	TC.. 110304	S	A40C

### 备件 | Accessory

产品型号 Product ID	①	②	③	④	⑤	⑥					
	桥架式刀座 Bridge Adaptor	滑块 Slide	配重滑块 Slide(CW)	精镗刀座 Adaptor	配重块 Counter-Weight	刀夹 Cartridge	刀片螺钉扳手 Key(Insert)	调整螺钉扳手 Key(Adj.)	锁紧螺钉扳手 Key(Screw)	螺钉扳手 Key(Screw)	
BFD-160230-TC1102-S-A40C-EW	BPDB-A40C-160050	BPFB-SL-160	BPFB-SL-160CW	BPFD-CY34-050025-EW	BPFB-CW-5043A	BPFI-CA-1019TC1102-S	242.070.35	246.030.60	247.040.100	241.050.80	241.080.00
BFD-160230-TC1103-S-A40C-EW	BPDB-A40C-160050	BPFB-SL-160	BPFB-SL-160CW	BPFD-CY34-050025-EW	BPFB-CW-5043A	BPFI-CA-1019TC1103-S	242.070.35	246.030.60	247.040.100	241.050.80	241.080.00
BFD-215285-TC1102-S-A40C-EW	BPDB-A40C-215050	BPFB-SL-160	BPFB-SL-160CW	BPFD-CY34-050025-EW	BPFB-CW-5043A	BPFI-CA-1019TC1102-S	242.070.35	246.030.60	247.040.100	241.050.80	241.080.00
BFD-215285-TC1103-S-A40C-EW	BPDB-A40C-215050	BPFB-SL-160	BPFB-SL-160CW	BPFD-CY34-050025-EW	BPFB-CW-5043A	BPFI-CA-1019TC1103-S	242.070.35	246.030.60	247.040.100	241.050.80	241.080.00

- 可单独订购备件，按需询价

- The spare parts can be ordered separately. Please inquire on demand

## BFD-B 系列

BFD-B Series

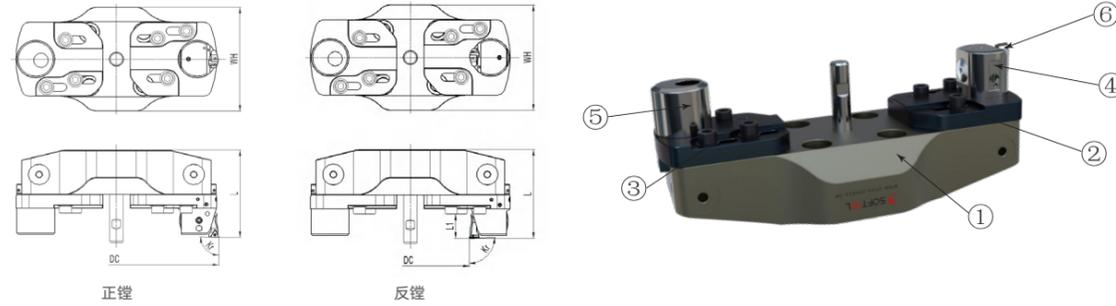

- 内冷却液供应
- TCMT TCMX TCGT TCGX TCEX TCMW
- 刀片仅做示意

- Internal coolant supply
- TCMT TCMX TCGT TCGX TCEX TCMW
- The insert is for illustration only

### 技术参数 | Technical parameters

单位 | Unit: mm

订货号 Ordering code	正镗 Positive boring			套镗 Sleeve boring			尺寸 Dimension					刀片 Insert	夹紧方式 Clamping	接口 Coupling
	镗削范围 Boring Range(DC)			镗削范围 Boring Range(DC)			L	L1	WH	Kr	KG			
	Min.	Max.	Adj.	Min.	Max.	Adj.								
BFD-270365-TC1102-S-A60C-EW	270	365	95	145	240	95	126	39	140	92	7.8	TC.. 110204	S	A60C
BFD-270365-TC1103-S-A60C-EW	270	365	95	145	240	95	126	39	140	92	7.8	TC.. 110304	S	A60C
BFD-350445-TC1102-S-A60C-EW	350	445	95	225	320	95	131	39	140	92	9.6	TC.. 110204	S	A60C
BFD-350445-TC1103-S-A60C-EW	350	445	95	225	320	95	131	39	140	92	9.6	TC.. 110304	S	A60C
BFD-430525-TC1102-S-A60C-EW	430	525	95	305	400	95	136	39	140	92	11.4	TC.. 110204	S	A60C
BFD-430525-TC1103-S-A60C-EW	430	525	95	305	400	95	136	39	140	92	11.4	TC.. 110304	S	A60C

### 备件 | Accessory

产品型号 Product ID	①	②	③	④	⑤	⑥					
	桥架式刀座 Bridge Adaptor	滑块 Slide	配重滑块 Slide(CW)	精镗刀座 Adaptor	配重块 Counter-Weight	刀夹 Cartridge	刀片螺钉扳手 Key(Insert)	调整螺钉扳手 Key(Adj.)	锁紧螺钉扳手 Key(Screw)	螺钉扳手 Key(Screw)	螺钉扳手 Key(Screw)
BFD-270365-TC1102-S-A60C-EW	BPDB-A60C-270060	BPFB-SL-270	BPFB-SL-270CW	BPFD-CY34-050025-EW	BPFB-CW-5043A	BPFI-CA-1019TC1102-S	242.070.35	246.030.60	247.040.100	241.050.80	241.080.00
BFD-270365-TC1103-S-A60C-EW	BPDB-A60C-270060	BPFB-SL-270	BPFB-SL-270CW	BPFD-CY34-050026-EW	BPFB-CW-5043A	BPFI-CA-1019TC1103-S	242.070.35	246.030.60	247.040.100	241.050.80	241.080.00
BFD-350445-TC1102-S-A60C-EW	BPDB-A60C-350065	BPFB-SL-270	BPFB-SL-270CW	BPFD-CY34-050027-EW	BPFB-CW-5043A	BPFI-CA-1019TC1102-S	242.070.35	246.030.60	247.040.100	241.050.80	241.080.00
BFD-350445-TC1103-S-A60C-EW	BPDB-A60C-350065	BPFB-SL-270	BPFB-SL-270CW	BPFD-CY34-050028-EW	BPFB-CW-5043A	BPFI-CA-1019TC1103-S	242.070.35	246.030.60	247.040.100	241.050.80	241.080.00
BFD-430525-TC1102-S-A60C-EW	BPDB-A60C-430070	BPFB-SL-270	BPFB-SL-270CW	BPFD-CY34-050029-EW	BPFB-CW-5043A	BPFI-CA-1019TC1102-S	242.070.35	246.030.60	247.040.100	241.050.80	241.080.00
BFD-430525-TC1103-S-A60C-EW	BPDB-A60C-430070	BPFB-SL-270	BPFB-SL-270CW	BPFD-CY34-050030-EW	BPFB-CW-5043A	BPFI-CA-1019TC1103-S	242.070.35	246.030.60	247.040.100	241.050.80	241.080.00

• 可单独订购备件, 按需询价

• The spare parts can be ordered separately. Please inquire on demand

## BFD-B 系列滑块

BFD-B Series Slide



### > 技术参数 | Technical parameters

单位 | Unit: mm

订货号 Ordering code	直径范围 Fitting Range
BPFB-SL-160	160-285
BPFB-SL-270	270-525

产品型号 Product ID	备件   Accessary				单独订购   Purchase Separately
	① 堵丝 Nozzle	② 堵丝 Nozzle	③ 调整螺钉 Screw(Adj.)	④ 堵丝 Nozzle	调整螺钉扳手 Key(Adj.)
BPFB-SL-160	-	251.050.05	-	-	-
BPFB-SL-270	251.040.04	251.050.05	214.020.368	254.030.10	246.030.60

- 可单独订购备件，按需询价
- BFD-B 系列滑块与 BFB 系列滑块通用

- The spare parts can be ordered separately. Please inquire on demand
- BFD-B series slide and BFB series slide used interchangeably

## BFD-B 系列配重滑块

BFD-B Series Slide(CW)



### > 技术参数 | Technical parameters

单位 | Unit: mm

订货号 Ordering code	直径范围 Fitting Range
BPFB-SL-160CW	160-285
BPFB-SL-270CW	270-525

产品型号 Product ID	备件   Accessary		单独订购   Purchase Separately
	① 调整螺钉 Screw(Adj.)	② 堵丝 Nozzle	调整螺钉扳手 Key(Adj.)
BPFB-SL-160CW	-	-	-
BPFB-SL-270CW	214.020.368	254.030.10	246.030.60

- 可单独订购备件，按需询价
- BFD-B 系列配重滑块与 BFB 系列配重滑块通用

- The spare parts can be ordered separately. Please inquire on demand
- BFD-B series slide(CW) and BFB series slide(CW) used interchangeably

## BFD-B 系列精镗刀座

BFD-B Series Adaptor

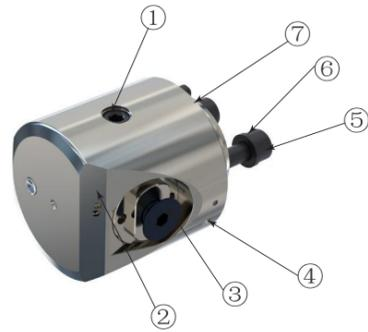

### > 技术参数 | Technical parameters

单位 | Unit: mm

订货号 Ordering code	直径范围 Fitting Range
BPFB-CY34-050025	160-525

产品型号 Product ID	备件   Accessory							单独订购   Purchase Separately	
	① 锁紧螺钉 Screw(Lock)	② 堵丝 Nozzle	③ 刀夹锁紧螺钉 Screw(Cartridge)	④ 堵丝 Nozzle	⑤ 螺钉 Screw	⑥ 垫圈 Gasket	⑦ 圆柱销 Pin	螺钉扳手 Key(Screw)	锁紧螺钉扳手 Key(Screw)
BPFB-CY34-050025	119.080.12	251.020.03	111.080.12	251.030.03	113.060.20	131.060.16	171.050.12	241.050.80	247.040.100

- 可单独订购备件，按需询价

- The spare parts can be ordered separately. Please inquire on demand

## BFD-B 系列配重块

BFD-B Series Counter-Weight

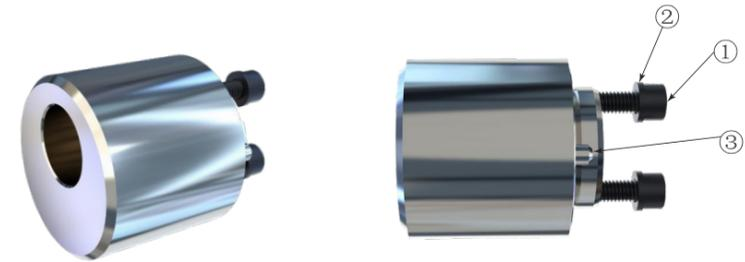

### > 技术参数 | Technical parameters

单位 | Unit: mm

订货号 Ordering code	直径范围 Fitting Range
BPFB-CW-5043A	160-525

产品型号 Product ID	备件   Accessory			单独订购   Purchase Separately
	① 螺钉 Screw	② 垫圈 Gasket	③ 圆柱销 Pin	螺钉扳手 Key(Screw)
BPFB-CW-5043A	113.060.20	131.060.16	171.050.12	241.050.80

- 可单独订购备件，按需询价
- BFD-B 系列配重块与 BFB 系列配重块通用

- The spare parts can be ordered separately. Please inquire on demand
- BFD-B series counter-weight and BFB series counter-weight used interchangeably

## 数显精镗刀BFD-H插杆系列

DIGITAL DISPLAY FINE-BORING BFD-H SERIES

### 01

具备机械式精镗刀的所有优点

Possesses all the advantages of a mechanical precision boring tool

### 03

刀具直径调节精度0.001mm

The tool diameter adjustment precision is 0.001mm

### 05

可以检测出锁紧螺钉引起的刀尖位移变化量，保证调节精度

The system can detect changes in tool tip displacement caused by the tightening of locking screws, ensuring adjustment precision

### 02

刀具调节可视化，方便且直观

The tool adjustment is visual, convenient, and intuitive

### 04

显示精度为刀尖实际位移，避免螺纹副引起的误差

Display the precision as the actual displacement of the tool tip to avoid errors caused by thread engagement



## BFD-H 插杆系列

BFD Series

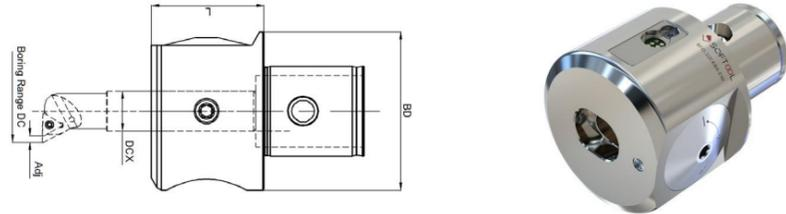

- 内冷却液供应
- TCMT TCMX TCGT TCGX TCEX TCMW
- 刀片仅做示意

- Internal coolant supply
- TCMT TCMX TCGT TCGX TCEX TCMW
- The insert is for illustration only

### › 技术参数 | Technical parameters

订货号 Ordering code	尺寸 Dimension					接口 Coupling
	L	BD	DCX	Adj.	Kg	
BFD-10CKB4-EW	33.5	39	10	2	0.28	CKB4
BFD-12CKB5-EW	36	50	12	3.5	0.5	CKB5
BFD-16CKB6-EW	45	63.5	16	4.5	1.1	CKB6

### › 备件 | Accessory

产品型号 Product ID	①	②	
	锁紧螺钉 Screw(Lock)	锁紧螺钉 Screw(Lock)	
BFD-10CKB4-EW	119.060.10	251.060.05	247.030.100
BFD-12CKB5-EW	119.080.12	251.080.06	247.040.100
BFD-16CKB6-EW	119.100.16	251.100.08	247.050.100

- 可单独订购备件，按需询价

- The spare parts can be ordered separately. Please inquire on demand

## 数字化镗刀显示器

Display

› 订货号: BFD-FAST



› 适用于所有数字化镗刀  
Suitable for all digital boring tools

› 注意使用前，需保证接口处清洁，避免显示器短路  
Please ensure that the interface is clean before use to avoid short-circuiting the display

› 使用 7 号普通电池  
Use regular size 7 batteries



## 夹套 Jacket

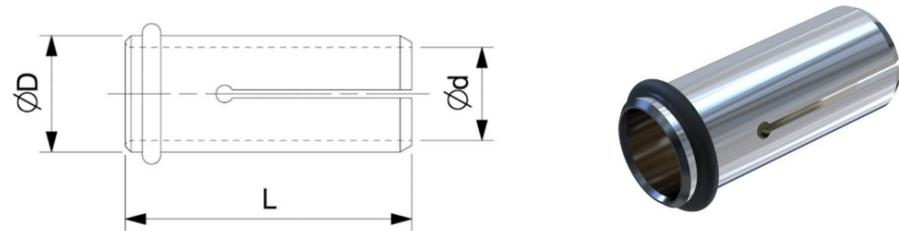

### > 技术参数 | Technical parameters

单位 | Unit: mm

订货号 Ordering code	尺寸 Dimension			重量 Weight
	D	d	L	
RS1008	10	8	24.5	0.001
RS1208	12	8	30	0.001
RS1210	12	10	30	0.001
RS1608	16	8	36	0.005
RS1610	16	10	36	0.005
RS1612	16	12	36	0.005
RS1614	16	14	36	0.005

- BFD-H 夹套与 BFH 夹套通用

- BFD-H jacket and BFH jacket can be used interchangeably

### > 命名方式 | Naming And Coding Rules



## 侧固式连接杆 Side-clamped Connection Rod

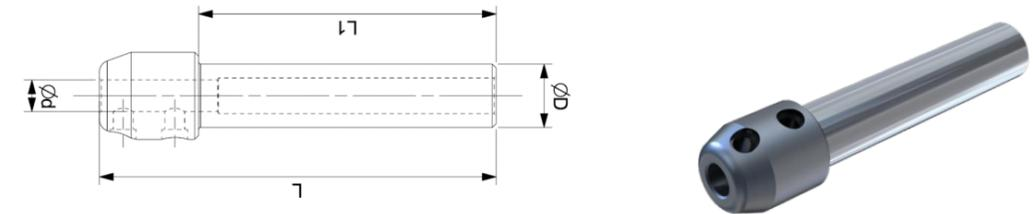

- 内冷却液供应

- Internal coolant supply

### > 技术参数 | Technical parameters

单位 | Unit: mm

订货号 Ordering code	尺寸 Dimension				重量 Weight
	D	d	L	L1	
CY16-SLN8	16	8	100	75	0.137
CY16-SLN10	16	10	100	75	0.127

### > 备件 | Accessory

产品型号 Product ID	螺钉 Key	螺钉扳手 Key(Screw)
CY16-SLN8	259.060.06	241.030.63
CY16-SLN10	259.060.06	241.030.63

- 可单独订购备件，按需询价
- BFD-H 侧固式连接杆与 BFH 侧固式连接杆通用

- The spare parts can be ordered separately. Please inquire on demand
- BFD-H side-clamped connection rod and BFH side-clamped connection rod used interchangeably

### > 命名方式 | Naming And Coding Rules



**镗刀杆**  
Boring Bar

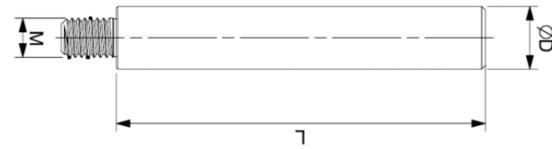

• 内冷却液供应

• Internal coolant supply

> 技术参数 | Technical parameters

单位 | Unit: mm

订货号 Ordering code	尺寸 Dimension			适配镗刀头 Suitable for boring head	重量 Weight
	D	M	L		
CY08-M5-47	8	M5	47	BS09-TP08-M5 BS10.5-TP08-M5	0.014
CY08CR-M5-72	8	M5	72		0.040
CY08CR-M5-87	8	M5	87		0.050
CY10-M6-52	10	M6	52	BS12-TP08-M6 BS14-TP08-M6 BS16-TP08-M6	0.025
CY10CR-M6-77	10	M6	77		0.070
CY10CR-M6-97	10	M6	97		0.090
CY10-M10-58	10	M10	58	BS18-TP08-M10 BS20-TP08-M10	0.035
CY12-M6-77	12	M6	77	BS14-TP08-M6 BS16-TP08-M6	0.057
CY12CR-M6-107	12	M6	107		0.160
CY12CR-M6-137	12	M6	137		0.210
CY12-M10-72	12	M10	72	BS18-TP08-M10 BS20-TP08-M10 BS22-TP08-M10 BS24-TP08-M10 BS26-TP08-M10 BS28-TP08-M10 BS30-TP08-M10	0.065
CY12CR-M10-112	12	M10	112		0.200
CY12CR-M10-142	12	M10	142		0.240

转下页 see next page →

**镗刀杆**  
Boring Bar

> 备件 | Accessory

订货号 Ordering code	尺寸 Dimension			适配镗刀头 Suitable for boring head	重量 Weight
	D	M	L		
CY14-M6-87	14	M6	87	BS16-TP08-M6	0.980
CY14CR-M6-117	14	M6	117		0.290
CY14CR-M6-147	14	M6	147		0.312
CY16-M10-88	16	M10	88	BS18-TP08-M10 BS20-TP08-M10 BS22-TP08-M10 BS24-TP08-M10 BS26-TP08-M10 BS28-TP08-M10 BS30-TP08-M10 BS32-TP08-M10 BS34-TP08-M10 BS36-TP08-M10 BS38-TP08-M10 BS40-TP08-M10 BS42-TP08-M10 BS46-TP08-M10	0.130
CY16CR-M10-108	16	M10	108		0.300
CY16CR-M10-168	16	M10	168		0.460

• 注：型号中带“CR”的是硬质合金镗刀杆  
• BFD-H 镗刀杆与 BFH 镗刀杆通用

• Note: The models with "CR" are cemented carbide boring bars  
• BFD-H boring bar and BFH boring bar used interchangeably

> 命名方式 | Naming And Coding Rules



**镗刀头**  
Boring Head

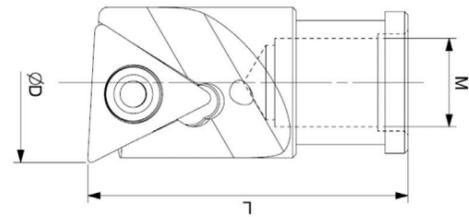

• 内冷却液供应

• Internal coolant supply

> 技术参数 | Technical parameters

单位 | Unit: mm

订货号 Ordering code	尺寸 Dimension			刀片 Insert	重量 Weight
	M	L	D		
BS09-TP08-M5	M5	18	9-11	TP.080202	0.004
BS10.5-TP08-M5	M5	18	10.5-12.5	TP.080202	0.005
BS12-TP08-M6	M6	23	12-14	TP.080202	0.007
BS14-TP08-M6	M6	23	14-16	TP.080202	0.009
BS16-TP08-M6	M6	23	16-18	TP.080202	0.012
BS18-TP08-M10	M10	27	18-20	TP.080202	0.017
BS20-TP08-M10	M10	27	20-22	TP.080202	0.024
BS22-TP08-M10	M10	27	22-24	TP.080202	0.025
BS24-TP08-M10	M10	27	24-26	TP.080202	0.026
BS26-TP08-M10	M10	27	26-28	TP.080202	0.028
BS28-TP08-M10	M10	27	28-30	TP.080202	0.029
BS30-TP08-M10	M10	27	30-32	TP.080202	0.029
BS32-TP08-M10	M10	27	32-34	TP.080202	0.030
BS34-TP08-M10	M10	27	34-36	TP.080202	0.030
BS36-TP08-M10	M10	27	36-38	TP.080202	0.031
BS38-TP08-M10	M10	27	38-40	TP.080202	0.031
BS40-TP08-M10	M10	27	40-42	TP.080202	0.031
BS42-TP08-M10	M10	27	42-46	TP.080202	0.033
BS46-TP08-M10	M10	27	46-50	TP.080202	0.034

转下页 see next page →

**镗刀头**  
Boring Head

> 备件 | Accessory

刀片 Insert	刀片螺钉 Screw(Insert)	刀片螺钉扳手 Key(Insert)
TP.080202	ILD2249	242.070.35

- 可单独订购备件, 按需询价
- BFD-H 镗刀头与 BFH 镗刀头通用

- The spare parts can be ordered separately. Please inquire on demand
- BFD-H boring head and BFH boring head used interchangeably

> 命名方式 | Naming And Coding Rules



# 精镗刀BFG系列

FINE-BORING BFG SERIES

## 01

用于 $\Phi 200$ - $\Phi 550$ mm的孔径精加工  
Apply to  $\Phi 200$ - $\Phi 550$ mm aperture finishing

## 03

航空铝桥架具有较轻的重量  
可减少主轴负载

Aviation aluminum bridge with less  
weight can reduce the spindle load

## 05

可进行径向调节  
Radial adjustment is available

## 02

加工孔径公差可达IT6级  
Machining aperture tolerance can  
reach IT6

## 04

直径调节精度0.01mm  
Diameter adjustment accuracy: 0.01mm

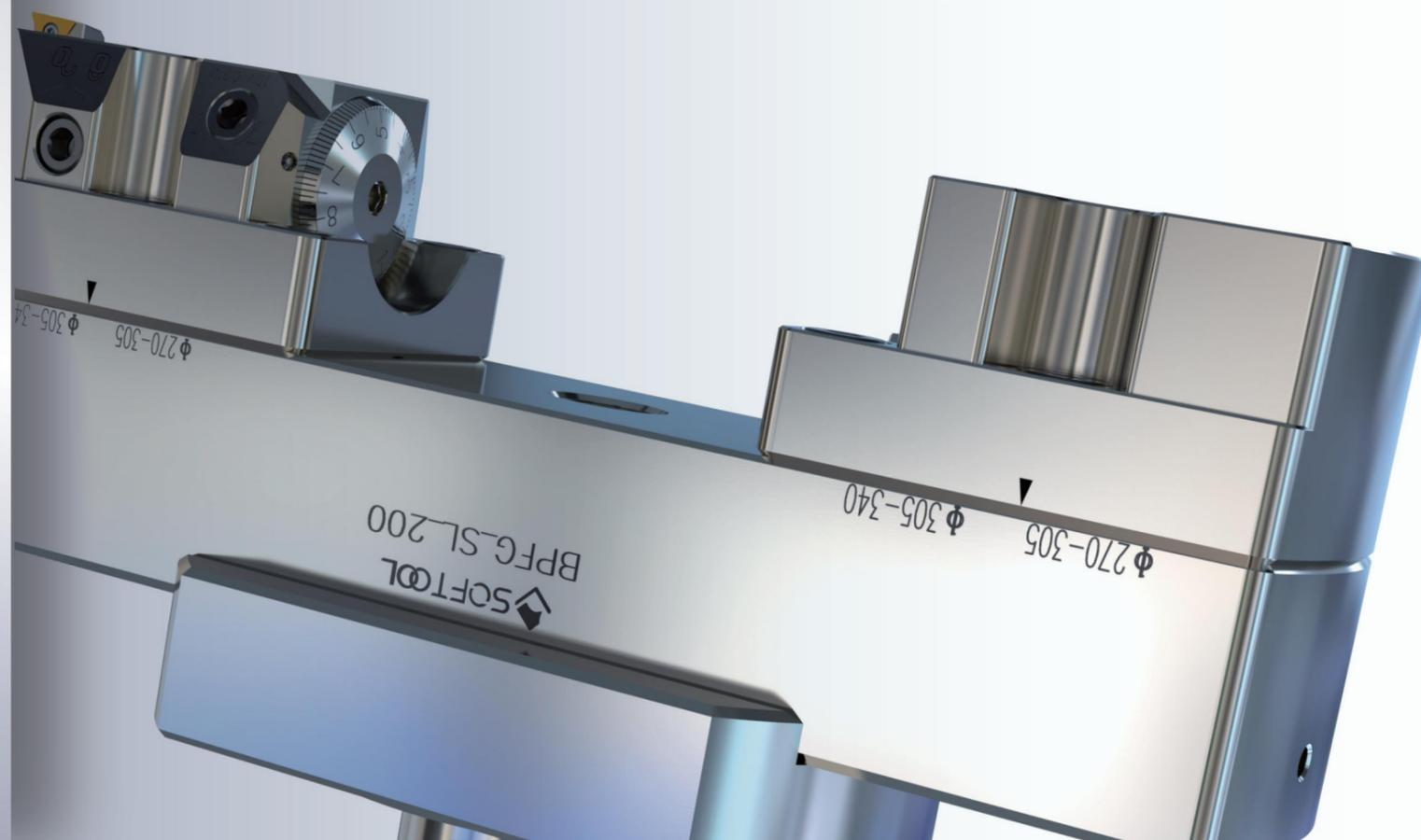

## BFG-TC 系列

BFG-TC Series

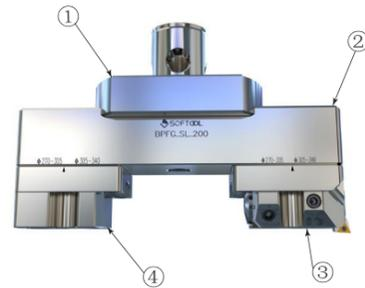
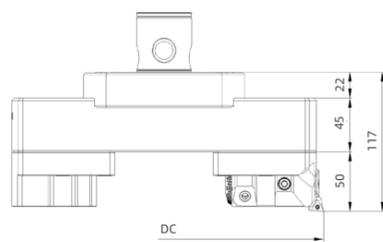

镗削范围 Boring Range		法兰座① Flange Adaptor		桥架式刀座② Bridge Adaptor ②		精镗头③ Adaptor ③		配重块④ Counter-Weight ④		刀片 Insert
		型号 (重量) Product ID (kg)	重量 (kg)	型号 Product ID	重量 (kg)	型号 Product ID	重量 (kg)	型号 Product ID	重量 (kg)	
200	270	CKB7-FLN135 (2.76kg)	1.44	BLN200-270AL	1.44	BFG200	1.44	BFG200CW	1.44	TC..110204
270	340			BLN270-340AL	2.04	BFG200	1.44	BFG200CW	1.44	TC..110204
340	410	PSC80-FLN135(3.8kg)	2.64	BLN340-410AL	1.44	BFG200	1.44	BFG200CW	1.44	TC..110204
410	480			BLN410-480AL	3.24	BFG200	1.44	BFG200CW	1.44	TC..110204
480	550	PSC80-FLN135.90(3.8kg)	3.84	BLN480-550AL	1.44	BFG200	1.44	BFG200CW	1.44	TC..110204

- 精镗头附带刀夹 FNH7-1，如需其他刀夹需单独订购
- 不附带刀片
- 标准品的刀尖与传动键槽同相位（法兰座的刀尖与传动键槽成 90°）

- The fine boring head comes with the FNH7-1 holder, other holders must be ordered separately
- Blades not included
- The tip of the standard product is in phase with the drive keyway (the tip of flange holders CKB7-FLN135.90, PSC80-FLN135.90 is at 90° to the drive keyway)

## BFG-TC 系列

BFG-TC Series

### 技术参数 | Technical parameters

单位 | Unit: mm

订货号 Ordering code	镗削范围 Boring Range		法兰座 Flange seat	桥架式刀座 Adaptor	刀片 Insert
BFG-200270-CKB7-FLN135-TC1102	200	270	CKB7-FLN135	BLN200-270AL	TC1102
BFG-200270-CKB7-FLN135.90-TC1102	200	270	CKB7-FLN135.90	BLN200-270AL	TC1102
BFG-200270-PSC80-FLN135-TC1102	200	270	PSC80-FLN135	BLN200-270AL	TC1102
BFG-200270-PSC80-FLN135.90-TC1102	200	270	PSC80-FLN135.90	BLN200-270AL	TC1102
BFG-270340-CKB7-FLN135-TC1102	200	270	CKB7-FLN135	BLN270-340AL	TC1102
BFG-270340-CKB7-FLN135.90-TC1102	270	340	CKB7-FLN135.90	BLN270-340AL	TC1102
BFG-270340-PSC80-FLN135-TC1102	270	340	PSC80-FLN135	BLN270-340AL	TC1102
BFG-270340-PSC80-FLN135.90-TC1102	270	340	PSC80-FLN135.90	BLN270-340AL	TC1102
BFG-340410-CKB7-FLN135-TC1102	340	410	CKB7-FLN135	BLN340-410AL	TC1102
BFG-340410-CKB7-FLN135.90-TC1102	340	410	CKB7-FLN135.90	BLN340-410AL	TC1102
BFG-340410-PSC80-FLN135-TC1102	340	410	PSC80-FLN135	BLN340-410AL	TC1102
BFG-340410-PSC80-FLN135.90-TC1102	340	410	PSC80-FLN135.90	BLN340-410AL	TC1102
BFG-410480-CKB7-FLN135-TC1102	410	480	CKB7-FLN135	BLN410-480AL	TC1102
BFG-410480-CKB7-FLN135.90-TC1102	410	480	CKB7-FLN135.90	BLN410-480AL	TC1102
BFG-410480-PSC80-FLN135-TC1102	410	480	PSC80-FLN135	BLN410-480AL	TC1102
BFG-410480-PSC80-FLN135.90-TC1102	410	480	PSC80-FLN135.90	BLN410-480AL	TC1102
BFG-480550-CKB7-FLN135-TC1102	480	550	CKB7-FLN135	BLN480-550AL	TC1102
BFG-480550-CKB7-FLN135.90-TC1102	480	550	CKB7-FLN135.90	BLN480-550AL	TC1102
BFG-480550-PSC80-FLN135-TC1102	480	550	PSC80-FLN135	BLN480-550AL	TC1102
BFG-480550-PSC80-FLN135.90-TC1102	480	550	PSC80-FLN135.90	BLN480-550AL	TC1102

### 命名方式 | Naming And Coding Rules

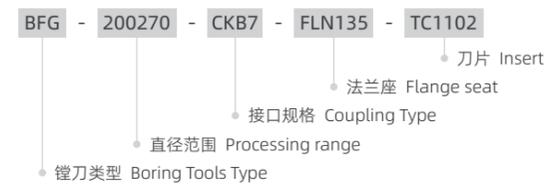

**BFG 系列刀夹**  
BFG Series Cartridge

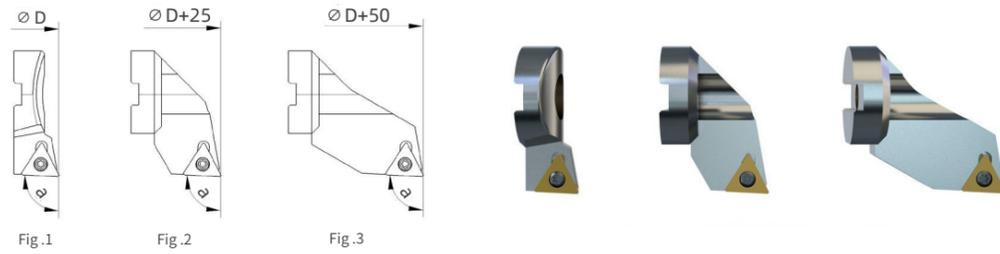

› 技术参数 | Technical parameters

单位 | Unit: mm

订货号 Ordering code	Fig	主偏角 I (a)Kr	刀片   Insert	刀片螺钉 Insert screw	刀片螺钉扳手 Key(Insert)
FNH7-1	1	93°	TC..110204	SFS2565	242.070.35
FNH7-2	2	93°	TC..110204	SFS2565	242.070.35
FNH7-3	3	93°	TC..110204	SFS2565	242.070.35

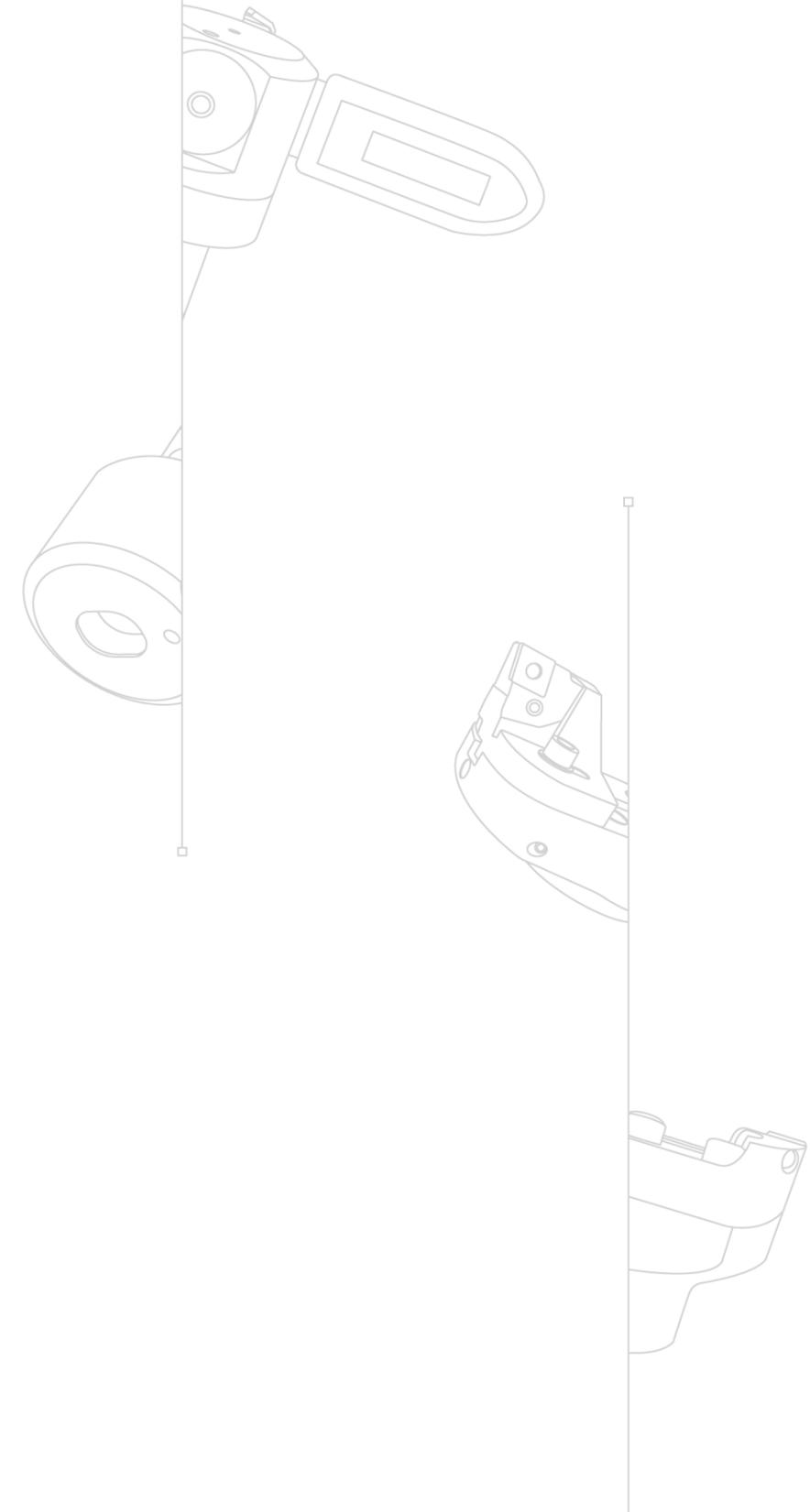

镗刀转接柄  
BORING TOOL  
ADAPTOR & HOLDER



01

包含两种系列：CK基础柄系列 芯轴基础柄系列

Two connection series: CK, Arbor

## 镗刀转接柄命名方式

Naming And Coding Rules



01 主接口规格 Coupling Type			
BT	SK	HSK	CK
BT30	SK30	HSK40A	CK1
BT40	SK40	HSK50A	CK2
BT50	SK50	HSK63A	CK3
		HSK100A	CK4
			CK5
			CK6
			CK7

02 转换接口规格 Chuck Type	
Arbor	CK
22	CK1
32	CK2
40	CK3
60	CK4
	CK5
	CK6
	CK7

03 有效长度 Length			
30mm	60mm	100mm	160mm
36mm	63mm	101mm	165mm
37mm	67mm	105mm	170mm
41mm	70mm	106mm	180mm
42mm	72mm	110mm	200mm
45mm	74mm	115mm	205mm
47mm	75mm	125mm	210mm
50mm	80mm	130mm	215mm
51mm	85mm	135mm	250mm
54mm	90mm	140mm	270mm
55mm	91mm	145mm	275mm
56mm	93mm	150mm	300mm
58mm	96mm	155mm	350mm

- 注：镗刀头接口规格 CKB 与镗刀接柄 CK 属于同一接口规格，配合使用
- Note: Boring tool head with CKB interface can match boring tool connection CK series. Their interface specifications are consistent

## CK 基础柄 PSC 系列

CK Connection with HSK Adaptor

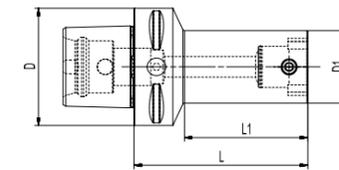

### 技术参数 | Technical parameters

单位 | Unit: mm

订货号 Ordering code	D	D1	L	L1	侧固螺钉 Screw (Side-fixed)	扳手 Key	重量 Weight
PSC40-CKB1-48	40	19	47.5	22	261.040.05	241.020.50	0.4
-CKB2-45	40	24	44.5	19	261.050.06	241.025.56	0.4
-CKB3-40	40	31	40	17	261.060.08	241.030.63	0.5
-CKB4-33	40	39	33	15	261.080.11	241.040.70	0.5
PSC50-CKB1-73	50	19	72.5	47	261.040.05	241.020.50	0.5
-CKB2-85	50	24	84.5	60	261.050.06	241.025.56	0.6
-CKB3-55	50	31	55	30	261.060.08	241.030.63	0.6
-CKB4-48	50	39	48	24	261.080.11	241.040.70	0.6
-CKB5-50	50	50	50	-	261.100.14	241.050.80	0.6
-CKB6-50	50	64	50	-	261.120.18	241.060.90	1.0
PSC63-CKB1-78	63	19	77.5	50	261.040.05	241.020.50	1.2
-CKB2-90	63	24	89.5	62	261.050.06	241.025.56	1.3
-CKB3-65	63	31	65	38	261.060.08	241.030.63	1.3
-100	63	31	100	73	261.060.08	241.030.63	1.5
-CKB4-58	63	39	58	31	261.080.11	241.040.70	1.3
-93	63	39	93	66	261.080.11	241.040.70	1.7
-CKB5-48	63	50	48	22	261.100.14	241.050.80	1.3
-83	63	50	83	57	261.100.14	241.050.80	1.7
-CKB6-59	63	64	59	-	261.120.18	241.060.90	1.6
-94	63	64	94	-	261.120.18	241.060.90	2.3

转下页 see next page →



## CK 基础柄 PSC 系列

CK Connection with HSK Adaptor

### 技术参数 | Technical parameters

单位 | Unit: mm

订货号 Ordering code	D	D1	L	L1	侧固螺钉 Screw (Side-fixed)	扳手 Key	重量 Weight
PSC80-CKB4-118	80	39	118	83	261.080.11	241.040.70	2.4
-178	80	39	178	143	261.080.11	241.040.70	3.0
-CKB5-108	80	50	108	73	261.100.14	241.050.80	2.7
-183	80	50	183	148	261.100.14	241.050.80	3.8
-CKB6-74	80	64	74	39	261.120.18	241.060.90	2.5
-169	80	64	169	135	261.120.18	241.060.90	4.8
-CKB7-73	80	90	73	-	261.200.29	241.100.00	3.1
-123	80	90	123	-	261.200.29	241.100.00	5.6

## CK 基础柄 HSK 系列

CK Connection with HSK Adaptor

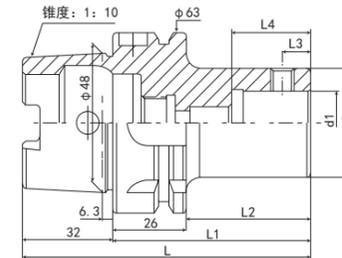

### 技术参数 | Technical parameters

单位 | Unit: mm

订货号 Ordering Code	L	L1	L2	L3	L4	d1	d2	侧固螺钉 Screw	重量 Weight
HSK63A-CK1-075	107	75	49	5.05	30	11	19	M4*0.5P	0.90
-105	137	105	79	5.05	30	11	19	M4*0.5P	0.90
-CK2-090	122	90	64	6.62	31	14	24	M5*0.5P	1.00
-120	152	120	94	6.62	31	14	24	M5*0.5P	1.00
-CK3-100	132	100	74	8	35	18	31	M6*0.75P	1.10
-135	167	135	109	8	35	18	31	M6*0.75P	1.30
-165	197	165	139	8	35	18	31	M6*0.75P	1.60
-CK4-090	122	90	64	10	39	22	39	M8*0.75P	1.30
-130	162	130	104	10	39	22	39	M8*0.75P	1.60
-170	202	170	144	10	39	22	39	M8*0.75P	2.00
-CK5-080	112	80	54	13	45	28	50	M10*1.0P	1.50
-135	167	135	109	13	45	28	50	M10*1.0P	2.20
-180	212	180	154	13	45	28	50	M10*1.0P	2.90
-215	247	215	189	13	45	28	50	M10*1.0P	3.40
-CK6-80	112	80	54	16	55	36	63	M12*1.0P	-
-115	147	115	89	16	55	36	63	M12*1.0P	-
-150	182	150	124	16	55	36	63	M12*1.0P	3.20
-180	212	180	154	16	55	36	63	M12*1.0P	3.90
-215	247	215	189	16	55	36	63	M12*1.0P	4.80
HSK100A-CK1-100	150	100	71	5.05	30	11	19	M4*0.5P	2.30
-145	195	145	116	5.05	30	11	19	M4*0.5P	2.60
-CK2-080	130	80	51	6.62	31	14	24	M5*0.5P	2.50
-115	165	115	86	6.62	31	14	24	M5*0.5P	2.60
-165	215	165	136	6.62	31	14	24	M5*0.5P	2.90

转下页 see next page →

## CK 基础柄 HSK 系列

CK Connection with HSK Adaptor

› 技术参数 | Technical parameters

单位 | Unit: mm

订货号 Ordering Code	L	L1	L2	L3	L4	d1	d2	侧固螺钉 Screw	重量 Weight
HSK100A-CK3-090	140	90	61	8	35	18	31	M6*0.75P	2.60
-125	175	125	96	8	35	18	31	M6*0.75P	2.80
-165	215	165	136	8	35	18	31	M6*0.75P	3.10
-CK4-120	170	120	91	10	39	22	39	M8*0.75P	3.00
-155	205	155	126	10	39	22	39	M8*0.75P	-
-180	230	180	151	10	39	22	39	M8*0.75P	3.60
-215	265	215	186	10	39	22	39	M8*0.75P	3.90
-CK5-110	160	110	81	13	45	28	50	M10*1.0P	3.20
-145	195	145	116	13	45	28	50	M10*1.0P	3.80
-180	230	180	151	13	45	28	50	M10*1.0P	4.30
-230	280	230	201	13	45	28	50	M10*1.0P	5.00
-270	320	270	241	13	45	28	50	M10*1.0P	5.50
-CK6-110	160	110	81	16	55	36	63	M12*1.0P	3.90
-145	195	145	116	16	55	36	63	M12*1.0P	4.70
-170	220	170	141	16	55	36	63	M12*1.0P	5.10
-230	280	230	201	16	55	36	63	M12*1.0P	6.50
-270	320	270	241	16	55	36	63	M12*1.0P	7.50
-300	350	300	271	16	55	36	63	M12*1.0P	8.30
-CK7-125	-	125	-	19.15	-	46	90	M20*1.0P	5.22
-200	-	200	-	19.15	-	46	90	M20*1.0P	6.88
-275	-	275	-	19.15	-	46	90	M20*1.0P	8.26

## CK 基础柄 BT 系列

CK Connection with BT Adaptor

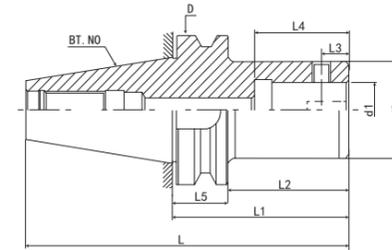

› 技术参数 | Technical parameters

单位 | Unit: mm

订货号 Ordering Code	L	L1	L2	L3	L4	L5	D	d1	d2	侧固螺钉 Screw	重量 Weight
BT30-CK1-055	103.4	55	33	5.05	30	22	46	11	19	M4*0.5P	0.70
-070	118.4	70	48	5.05	30	22	46	11	19	M4*0.5P	0.70
-CK2-080	128.4	80	58	6.62	31	22	46	14	24	M5*0.5P	0.80
-CK3-080	128.4	80	58	8	35	22	46	18	31	M6*0.75P	0.90
-CK4-070	118.4	70	48	10	39	22	46	22	39	M8*0.75P	1.00
-CK5-060	108.4	60	38	13	45	22	46	28	50	M10*1.0P	1.10
-CK6-060	108.4	60	38	16	55	22	46	36	63	M12*1.0P	1.20
BT40-CK1-075	140.4	75	48	5.05	30	27	63	11	19	M4*0.5P	1.00
-105	170.4	105	78	5.05	30	27	63	11	19	M4*0.5P	1.20
-CK2-085	150.4	85	58	6.62	31	27	63	14	24	M5*0.5P	1.20
-115	180.4	115	88	6.62	31	27	63	14	24	M5*0.5P	1.30
-CK3-095	160.4	95	68	8	35	27	63	18	31	M6*0.75P	1.10
-125	190.4	125	98	8	35	27	63	18	31	M6*0.75P	1.20
-155	220.4	155	128	8	35	27	63	18	31	M6*0.75P	1.60
-185	250.4	185	158	8	35	27	63	18	31	M6*0.75P	1.70
-CK4-085	150.4	85	58	10	39	27	63	22	39	M8*0.75P	1.45
-130	195.4	130	103	10	39	27	63	22	39	M8*0.75P	1.50
-175	240.4	175	148	10	39	27	63	22	39	M8*0.75P	2.10
-CK5-075	140.4	75	48	13	45	27	63	28	50	M10*1.0P	1.70
-125	190.4	125	98	13	45	27	63	28	50	M10*1.0P	1.95
-175	240.4	175	148	13	45	27	63	28	50	M10*1.0P	3.00
-CK6-065	130.4	65	38	16	55	27	63	36	63	M12*1.0P	2.15
-115	180.4	115	88	16	55	27	63	36	63	M12*1.0P	3.50
-165	230.4	165	138	16	55	27	63	36	63	M12*1.0P	3.85

转下页 see next page →

## CK 基础柄 BT 系列

CK Connection with BT Adaptor

### 技术参数 | Technical parameters

单位 | Unit: mm

订货号 Ordering Code	L	L1	L2	L3	L4	L5	D	d1	d2	侧固螺钉 Screw	重量 Weight
BT40-CK6-205	270.4	205	178	16	55	27	63	36	63	M12*1.0P	4.10
BT50-CK1-090	191.8	90	52	5.05	30	38	100	11	19	M4*0.5P	3.70
-115	216.8	115	77	5.05	30	38	100	11	19	M4*0.5P	3.90
-145	246.8	145	107	5.05	30	38	100	11	19	M4*0.5P	4.40
-CK2-090	191.8	90	52	6.62	31	38	100	14	24	M5*0.5P	3.80
-110	211.8	110	72	6.62	31	38	100	14	24	M5*0.5P	4.00
-140	241.8	140	102	6.62	31	38	100	14	24	M5*0.5P	5.00
-CK3-090	191.8	90	52	8	35	38	100	18	31	M6*0.75P	4.40
-125	226.8	125	87	8	35	38	100	18	31	M6*0.75P	4.40
-155	256.8	155	117	8	35	38	100	18	31	M6*0.75P	4.60
-CK4-090	191.8	90	52	10	39	38	100	22	39	M8*0.75P	4.60
-115	216.8	115	77	10	39	38	100	22	39	M8*0.75P	4.80
-145	246.8	145	107	10	39	38	100	22	39	M8*0.75P	4.70
-175	276.8	175	137	10	39	38	100	22	39	M8*0.75P	5.10
-205	306.8	205	167	10	39	38	100	22	39	M8*0.75P	5.40
-CK5-090	191.8	90	52	13	45	38	100	28	50	M10*1.0P	5.40
-105	206.8	105	67	13	45	38	100	28	50	M10*1.0P	5.50
-150	251.8	150	112	13	45	38	100	28	50	M10*1.0P	6.00
-180	281.8	180	142	13	45	38	100	28	50	M10*1.0P	6.20
-240	341.8	240	202	13	45	38	100	28	50	M10*1.0P	6.40
-270	371.8	270	232	13	45	38	100	28	50	M10*1.0P	6.70
-CK6-095	196.8	95	57	16	55	38	100	36	63	M12*1.0P	5.90
-150	251.8	150	112	16	55	38	100	36	63	M12*1.0P	6.50
-170	271.8	170	132	16	55	38	100	36	63	M12*1.0P	6.30
-205	306.8	205	167	16	55	38	100	36	63	M12*1.0P	6.90
-230	331.8	230	192	16	55	38	100	36	63	M12*1.0P	7.45
-270	371.8	270	232	16	55	38	100	36	63	M12*1.0P	8.20
-300	401.8	300	262	16	55	38	100	36	63	M12*1.0P	9.50
-350	451.8	350	312	16	55	38	100	36	63	M12*1.0P	10.80
-CK7-085	-	85	-	19.15	-	-	-	46	90	M20*1.0P	4.96
-150	-	150	-	19.15	-	-	-	46	90	M20*1.0P	6.52
-210	-	210	-	19.15	-	-	-	46	90	M20*1.0P	8.55
-250	-	250	-	19.15	-	-	-	46	90	M20*1.0P	10.35
-300	-	300	-	19.15	-	-	-	46	90	M20*1.0P	12.55
-350	-	350	-	19.15	-	-	-	46	90	M20*1.0P	13.25

## CK 基础柄 SK 系列

CK Connection with SK Adaptor

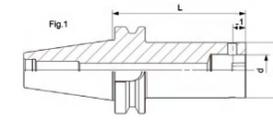

Fig 1

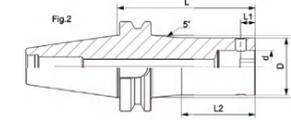

Fig 2



### 技术参数 | Technical parameters

单位 | Unit: mm

订货号 Ordering Code	Fig	D	d	d1	L1	L2	L	侧固螺钉 Screw (Side-fixed)	扳手 Key	重量 Weight
SK30-CK1-055	1	19	11	-	5.05	-	55	M5x5-30D	L025	0.42
-070	1	19	11	-	5.05	-	70	M5x5-30D	L025	0.45
-CK2-080	1	24	14	-	6.45	-	80	M5x6-30D	L025	0.54
-CK3-080	1	31	18	-	7.9	-	80	M6x9-30D	L03	0.68
-CK4-070	1	39	22	-	10	-	70	M8x12-30D	L04	0.68
-CK5-070	1	50	28	-	13	-	70	M10x16-30D	L05	0.88
-CK6-080	1	64	36	-	16	-	80	M12x20-30D	L06	0.89
SK40-CK1-070	1	19	11	-	5.05	-	70	M5x5-30D	L025	1.03
-100	2	19	11	20.7	5.05	60	100	M5x5-30D	L025	1.10
-CK2-075	1	24	14	-	6.45	-	75	M5x6-30D	L025	1.10
-100	1	24	14	-	6.45	-	100	M5x6-30D	L025	1.18
-130	2	24	14	28.3	6.45	75	130	M5x6-30D	L025	1.33
-160	2	24	14	33.6	6.45	75	160	M5x6-30D	L025	1.49
-CK3-080	1	31	18	-	7.9	-	80	M6x9-30D	L03	1.22
-100	1	31	18	-	7.9	-	100	M6x9-30D	L03	1.32
-135	2	31	18	34.5	7.9	85	135	M6x9-30D	L03	1.54
-165	2	31	18	39.7	7.9	85	165	M6x9-30D	L03	1.76
-CK4-070	1	39	22	-	10	-	70	M8x12-30D	L04	1.21
-100	1	39	22	-	10	-	100	M8x12-30D	L04	1.46
-150	2	39	22	43.4	10	95	150	M8x12-30D	L04	1.90
-170	2	39	22	46.9	10	95	170	M8x12-30D	L04	2.16
-CK5-080	1	50	28	-	13	-	80	M10x16-30D	L05	1.52
-100	1	50	28	-	13	-	100	M10x16-30D	L05	1.80
-150	1	50	28	-	13	-	150	M10x16-30D	L05	2.52

转下页 see next page →

## CK 基础柄 SK 系列

CK Connection with SK Adaptor

› 技术参数 | Technical parameters

单位 | Unit: mm

订货号 Ordering Code	Fig	D	d	d1	L1	L2	L	侧固螺钉 Screw (Side-fixed)	扳手 Key	重量 Weight
SK40-CK5-180	1	50	28	-	13	-	180	M10×16-30D	L05	2.90
-CK6-090	1	64	36	-	16	-	90	M12×20-30D	L06	2.29
-150	1	64	36	-	16	-	150	M12×20-30D	L06	3.50
-180	1	64	36	-	16	-	180	M12×20-30D	L06	4.22
SK50-CK1-080	2	19	11	20.7	5.05	-	80	M5×5-30D	L025	3.60
-115	2	19	11	20.7	5.05	60	115	M5×5-30D	L025	3.73
-145	2	19	11	26	5.05	60	145	M5×5-30D	L025	4.20
-CK2-080	1	24	14	-	6.45	-	80	M5×6-30D	L025	3.60
-105	1	24	14	-	6.45	-	105	M5×6-30D	L025	3.78
-135	2	24	14	26.6	6.45	75	135	M5×6-30D	L025	3.89
-165	2	24	14	31.9	6.45	75	165	M5×6-30D	L025	4.08
-CK3-085	1	31	18	-	7.9	-	85	M6×9-30D	L03	3.80
-110	1	31	18	-	7.9	-	110	M6×9-30D	L03	3.95
-140	2	31	18	32.7	7.9	85	140	M6×9-30D	L03	4.09
-170	2	31	18	38	7.9	85	170	M6×9-30D	L03	4.31
-CK4-100	1	39	22	-	10	-	100	M8×12-30D	L04	3.98
-160	2	39	22	42.5	10	95	160	M8×12-30D	L04	4.50
-205	2	39	22	50	10	95	205	M8×12-30D	L04	5.13
-CK5-090	1	50	28	-	13	-	90	M10×16-30D	L05	4.30
-165	1	50	28	-	13	-	165	M10×16-30D	L05	5.20
-210	2	50	28	57.8	13	120	210	M10×16-30D	L05	5.92
-270	2	50	28	68.4	13	120	270	M10×16-30D	L05	7.23
-CK6-085	1	64	36	-	16	-	85	M12×20-30D	L06	4.28
-155	1	64	36	-	16	-	155	M12×20-30D	L06	5.97
-215	1	64	36	-	16	-	215	M12×20-30D	L06	7.43
-250	1	64	36	-	16	-	250	M12×20-30D	L06	8.27
-300	2	64	36	80.5	16	160	300	M12×20-30D	L06	10.21
-CK7-085	1	90	46	-	19.15	-	85	M20×29-30D	L10	4.96
-150	1	90	46	-	19.15	-	150	M20×29-30D	L10	6.52
-210	1	90	46	-	19.15	-	210	M20×29-30D	L10	8.55
-250	1	90	46	-	19.15	-	250	M20×29-30D	L10	10.35
-300	1	90	46	-	19.15	-	300	M20×29-30D	L10	12.55
-350	1	90	46	-	19.15	-	350	M20×29-30D	L10	13.25

## CK 接口等径延长杆

Extension with CK Adaptor

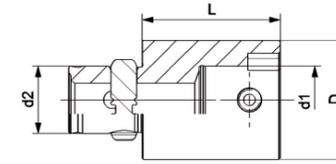

› 技术参数 | Technical parameters

单位 | Unit: mm

订货号 Ordering Code	D	d1	d2	L	侧固螺钉 Screw (Side-fixed)	扳手 Key	重量 Weight
CK1-CK1-030	19	11	11	30	M5×5-30D	L025	0.06
CK2-CK2-030	24	14	14	30	M5×6-30D	L025	0.09
CK3-CK3-030	31	18	18	30	M6×9-30D	L03	0.14
CK4-CK4-045	39	22	22	45	M8×12-30D	L04	0.29
-060	39	22	22	60	M8×12-30D	L04	0.47
CK5-CK5-060	50	28	28	60	M10×16-30D	L05	0.75
-090	50	28	28	90	M10×16-30D	L05	1.18
CK6-CK6-060	64	36	36	60	M12×20-30D	L06	1.46
-100	64	36	36	100	M12×20-30D	L06	2.35
CK7-CK7-105	90	46	46	105	M20×29-30D	L10	5.28

## CK 接口缩径杆

Reduction with CK Adaptor

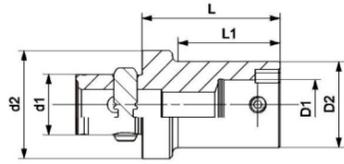

## 芯轴基础柄 BT 系列

Arbor Connection with BT Adaptor

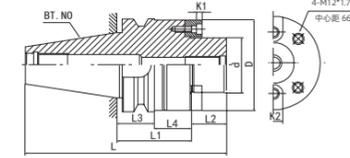
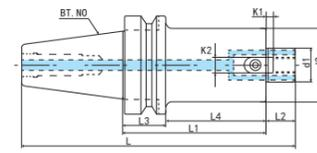

FIG:1

FIG:2

### 技术参数 | Technical parameters

单位 | Unit: mm

订货号 Ordering Code	D1	D2	d1	d2	L1	L	侧固螺钉 Screw (Side-fixed)	扳手 Key	重量 Weight
CK2-CK1-036	11	19	14	24	30	36	M5×5-30D	L025	0.08
CK3-CK1-041	11	19	18	31	30	41	M5×5-30D	L025	0.12
-CK2-037	14	24	18	31	25	37	M5×6-30D	L025	0.13
CK4-CK1-058	11	19	22	39	40	58	M5×5-30D	L025	0.24
-CK2-050	14	24	22	39	36	50	M5×6-30D	L025	0.22
-CK3-050	18	31	22	39	37	50	M6×9-30D	L03	0.30
CK5-CK1-060	11	19	28	50	40	60	M5×5-30D	L025	0.38
-CK2-054	14	24	28	50	35	54	M5×6-30D	L025	0.38
-074	14	24	28	50	55	74	M5×6-30D	L025	0.45
-CK3-047	18	31	28	50	29	47	M6×9-30D	L03	0.46
-072	18	31	28	50	54	72	M6×9-30D	L03	0.54
-CK4-042	22	39	28	50	25	42	M8×12-30D	L04	0.43
-067	22	39	28	50	50	67	M8×12-30D	L04	0.62
CK6-CK1-070	11	19	36	64	40	70	M5×5-30D	L025	0.90
-CK2-063	14	24	36	64	45	63	M5×6-30D	L025	0.66
-093	14	24	36	64	75	93	M5×6-30D	L025	0.71
-CK3-056	18	31	36	64	39	56	M6×9-30D	L03	0.70
-096	18	31	36	64	79	96	M6×9-30D	L03	0.91
-CK4-051	22	39	36	64	35	51	M8×12-30D	L04	0.76
-101	22	39	36	64	85	101	M8×12-30D	L04	1.19
-CK5-041	28	50	36	64	25	41	M10×16-30D	L05	0.72
-091	28	50	36	64	75	91	M10×16-30D	L05	1.46
CK7-CK6-106	36	64	46	90	99	106	M12×20-30D	L06	3.12

注：以上产品均可实现内冷结构

The products above can realize internal cooling

### 技术参数 | Technical parameters

单位 | Unit: mm

订货号 Ordering Code	L1	L	L2	L3	L4	d	D	K1	K2	四螺孔中心距 (PCD)	M	FIG	重量 Weight
BT30-FMB22-045	45	111.4	18	27	18	22	48	4.8	10	-	M10*1.5P	1	0.75
-060	60	126.4	18	27	33	22	48	4.8	10	-	M10*1.5P	1	1.50
-FMB32-045	45	115.4	22	27	18	32	63	6.8	14	-	M16*2.0P	1	1.50
-060	60	130.4	22	27	33	32	63	6.8	14	-	M16*2.0P	1	1.60
BT40-FMB22-060	60	143.4	18	27	33	22	44	4.8	10	-	M10*1.5P	1	1.50
-100	100	183.4	18	27	73	22	44	4.8	10	-	M10*1.5P	1	2.05
-150	150	233.4	18	27	123	22	44	4.8	10	-	M10*1.5P	1	2.75
-FMB32-060	60	147.4	22	27	33	32	63	6.8	14	-	M16*2.0P	1	1.90
-100	100	187.4	22	27	73	32	63	6.8	14	-	M16*2.0P	1	2.80
-150	150	237.4	22	27	123	32	63	6.8	14	-	M16*2.0P	1	3.60
-200	200	287.4	22	27	173	32	63	6.8	14	-	M16*2.0P	1	4.20
BT50-FMB22-060	60	179.8	18	38	22	22	44	4.8	10	-	M10*1.5P	1	4.60
-100	100	219.8	18	38	62	22	44	4.8	10	-	M10*1.5P	1	4.55
-150	150	269.8	18	38	112	22	44	4.8	10	-	M10*1.5P	1	5.25
-FMB32-060	60	183.8	22	38	22	32	70	6.8	14	-	M16*2.0P	1	4.65
-100	100	223.8	22	38	62	32	70	6.8	14	-	M16*2.0P	1	5.60
-150	150	273.8	22	38	112	32	70	6.8	14	-	M16*2.0P	1	7.85
-200	200	323.8	22	38	162	32	70	6.8	14	-	M16*2.0P	1	9.75
BT40-FMC40-060	60	150.4	25	27	33	40	99	8.3	16	66.7	-	2	2.80
-100	100	190.4	25	27	73	40	99	8.3	16	66.7	-	2	3.60
BT50-FMC40-060	60	186.4	25	38	22	40	99	8.3	16	66.7	-	2	5.50
-100	100	226.4	25	38	62	40	99	8.3	16	66.7	-	2	6.70
-150	150	276.4	25	38	112	40	99	8.3	16	66.7	-	2	7.50
-200	200	326.8	25	38	162	40	99	8.3	16	66.7	-	2	10.75

转下页 see next page →

## 芯轴基础柄 BT 系列

Arbor Connection with BT Adaptor

### > 技术参数 | Technical parameters

单位 | Unit: mm

订货号 Ordering Code	L1	L	L2	L3	L4	d	D	K1	K2	四螺孔中心距 (PCD)	M	FIG	重量 Weight
BT50-FMC40-250	250	376.8	25	38	212	40	99	8.3	16	66.7	-	2	14.00
-300	300	426.8	25	38	40	40	99	8.3	16	66.7	-	2	17.25
-FMC60-075	75	165.4	25	27	48	60	128.5	13	25.4	67.7	-	2	5.00
-075	75	201.8	25	38	37	60	128.5	13	25	68.7	-	2	8.50
-100	100	226.8	25	38	62	60	128.5	13	24.6	69.7	-	2	10.00
-150	150	276.8	25	38	112	60	128.5	13	24.2	101.6	-	2	13.50
-200	200	326.8	25	38	162	60	128.5	13	23.8	101.6	-	2	16.00
-250	250	376.8	25	38	212	60	128.5	13	23.4	101.6	-	2	19.00
-300	300	426.8	25	38	262	60	128.5	13	23	101.6	-	2	24.00
-350	350	476.8	25	38	312	60	128.5	13	22.6	101.6	-	2	28.00
-400	400	526.8	25	38	362	60	128.5	13	22.2	101.6	-	2	32.00
-450	450	576.8	25	38	412	60	128.5	13	21.8	101.6	-	2	36.00
-500	500	626.8	25	38	462	60	128.5	13	21.4	101.6	-	2	40.00

## 芯轴基础柄 HSK 系列

Arbor Connection with HSK Adaptor

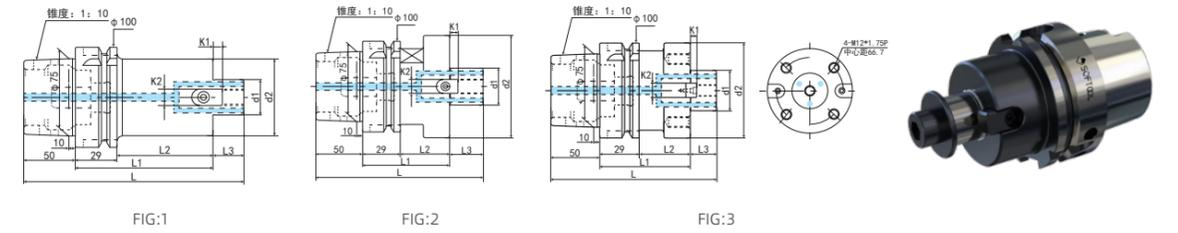

### > 技术参数 | Technical parameters

单位 | Unit: mm

订货号 Ordering Code	L	L1	L2	L3	d1	d2	K1	K2	M	FIG	重量 Weight
HSK63A-FMB22-050	100	50	24	18	22	47	4.8	10	M10*1.5P	1	1.20
-100	150	100	74	18	22	47	4.8	10	M10*1.5P	1	1.80
-150	200	150	124	18	22	47	4.8	10	M10*1.5P	1	2.50
-200	250	200	174	18	22	47	4.8	10	M10*1.5P	1	3.00
-FMB32-060	114	60	34	22	32	63	6.3	14	M16*2.0P	2	1.70
-100	154	100	74	22	32	63	6.3	14	M16*2.0P	2	2.30
-150	204	150	124	22	32	63	6.3	14	M16*2.0P	2	3.10
-200	254	200	174	22	32	63	6.3	14	M16*2.0P	2	3.90
HSK100A-FMB22-050	118	50	21	18	22	47	4.8	10	M16*2.6P	1	2.60
-100	168	100	71	18	22	47	4.8	10	M16*2.7P	1	3.30
-150	218	150	121	18	22	47	4.8	10	M16*2.8P	1	4.00
-FMB32-050	122	50	21	22	32	80	6.8	14	M16*2.0P	1	3.40
-100	172	100	71	22	32	80	6.8	14	M16*2.0P	1	5.30
-150	222	150	121	22	32	80	6.8	14	M16*2.0P	1	-
-200	272	200	171	22	32	80	6.8	14	M16*2.0P	1	9.30
-FMC40-060	135	60	31	25	40	100	8.3	16	-	3	-
-100	175	100	71	25	40	100	8.3	16	-	3	-
-150	225	150	121	25	40	100	8.3	16	-	3	8.10
-200	275	200	171	25	40	100	8.3	16	-	3	-
-FMC60-070	145	70	41	25	60	128	12.5	25	-	3	-
-100	175	100	71	25	60	128	12.5	25	-	3	-

## 芯轴基础柄 SK 系列

Arbor Connection with SK Adaptor

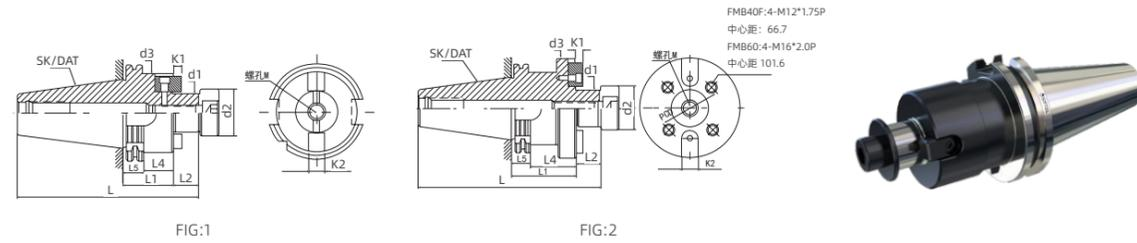

### 技术参数 | Technical parameters

单位 | Unit: mm

订货号 Ordering Code	L	L1	L2	L4	L5	d1	d2	d3	k1	k2	M	FIG
SK30-FMB22-035	100.8	35	18	16	19.1	22	26	48	4.8	10	M10*1.5P	1
SK40-FMB22-045	131.4	45	18	26	19.1	22	26	48	4.8	10	M10*1.5P	1
-060	146.4	60	18	41	19.1	22	26	48	4.8	10	M10*1.5P	1
-100	186.4	100	18	81	19.1	22	26	48	4.8	10	M10*1.5P	1
-150	236.4	150	18	131	19.1	22	26	48	4.8	10	M10*1.5P	1
-FMB32-045	110.4	45	22	26	19.1	32	40	70	6.8	14	M16*2.0P	1
-060	125.4	60	22	41	19.1	32	40	70	6.8	14	M16*2.0P	1
-100	165.4	100	22	81	19.1	32	40	70	6.8	14	M16*2.0P	1
SK50-FMB22-045	164.75	45	18	26	19.1	22	26	48	4.8	10	M10*1.5P	1
-060	179.75	60	18	41	19.1	22	26	48	4.8	10	M10*1.5P	1
-100	219.75	100	18	81	19.1	22	26	48	4.8	10	M10*1.5P	1
-150	269.75	150	18	131	19.1	22	26	48	4.8	10	M10*1.5P	1
-200	319.75	200	18	181	19.1	22	26	48	4.8	10	M10*1.5P	1
-FMB32-045	168.75	45	22	26	19.1	32	40	70	6.8	14	M16*2.0P	1
-060	183.75	60	22	41	19.1	32	40	70	6.8	14	M16*2.0P	1
-100	223.75	100	22	81	19.1	32	40	70	6.8	14	M16*2.0P	1
-150	273.75	150	22	231	19.1	32	40	70	6.8	14	M16*2.0P	1
-200	323.75	200	22	281	19.1	32	40	70	6.8	14	M16*2.0P	1
SK40-FMC40-060	153.4	60	25	66.7	19.1	40	-	99	8.3	16	M12*1.75P	2
SK50-FMC40-070	196.75	70	25	66.7	19.1	40	-	99	8.3	16	M12*1.75P	2
-100	226.75	100	25	66.7	19.1	40	-	99	8.3	16	M12*1.75P	2
-150	276.8	150	25	66.7	19.1	40	-	99	8.3	16	M12*1.75P	2
-200	326.8	200	25	66.7	19.1	40	-	99	8.3	16	M12*1.75P	2
-FMC60-070	196.75	70	25	101.6	19.1	60	-	128	12.5	25.4	M16*2.0P	2

## 转接柄

Transfer Adaptor

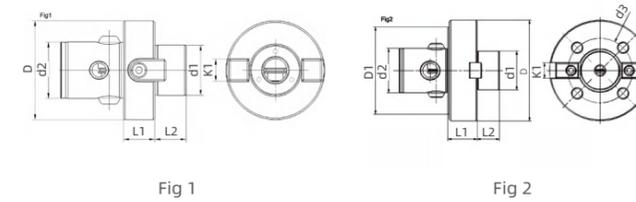

### 技术参数 | Technical parameters

单位 | Unit: mm

订货号 Ordering code	Fig	d1	d2	d3	D	D1	L1	L2	K1	螺栓 Screw	重量 Weight
CK4-FMB22-015M	1	22	22	-	40	-	15	16	10	113.100.35	0.30
CK5-FMB22-020M	1	22	28	-	50	-	20	16	10	113.100.35	0.42
CK6-FMB32-020M	1	32	36	-	63	-	20	20	14	113.160.40	0.93
-FMB40-030M	2	40	36	66.7	100	64	30	23	16	113.120.40	2.41
CK7-FMB32-030M	1	32	46	-	90	-	30	20	14	113.160.40	1.63
-FMC40-030M	2	40	46	66.7	100	90	30	23	16	113.120.40	2.67
-FMC60-035M	2	60	46	101.6	130	90	35	25	25.4	113.160.50	4.98

● 注：以上产品均可实现内冷结构

● The products above can realize internal cooling

## 刀具扩展组装示意图

Extended Tools Assembly View

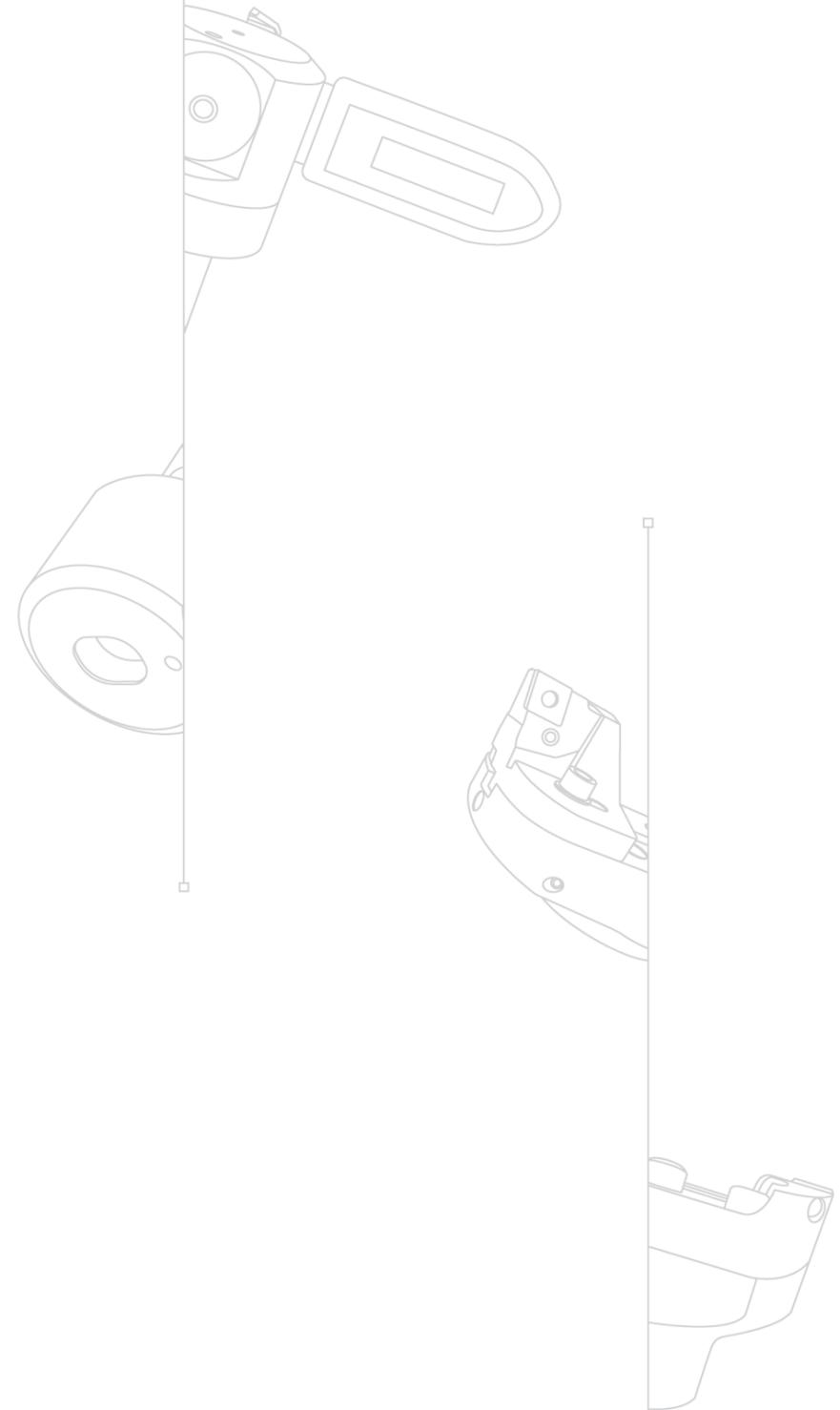
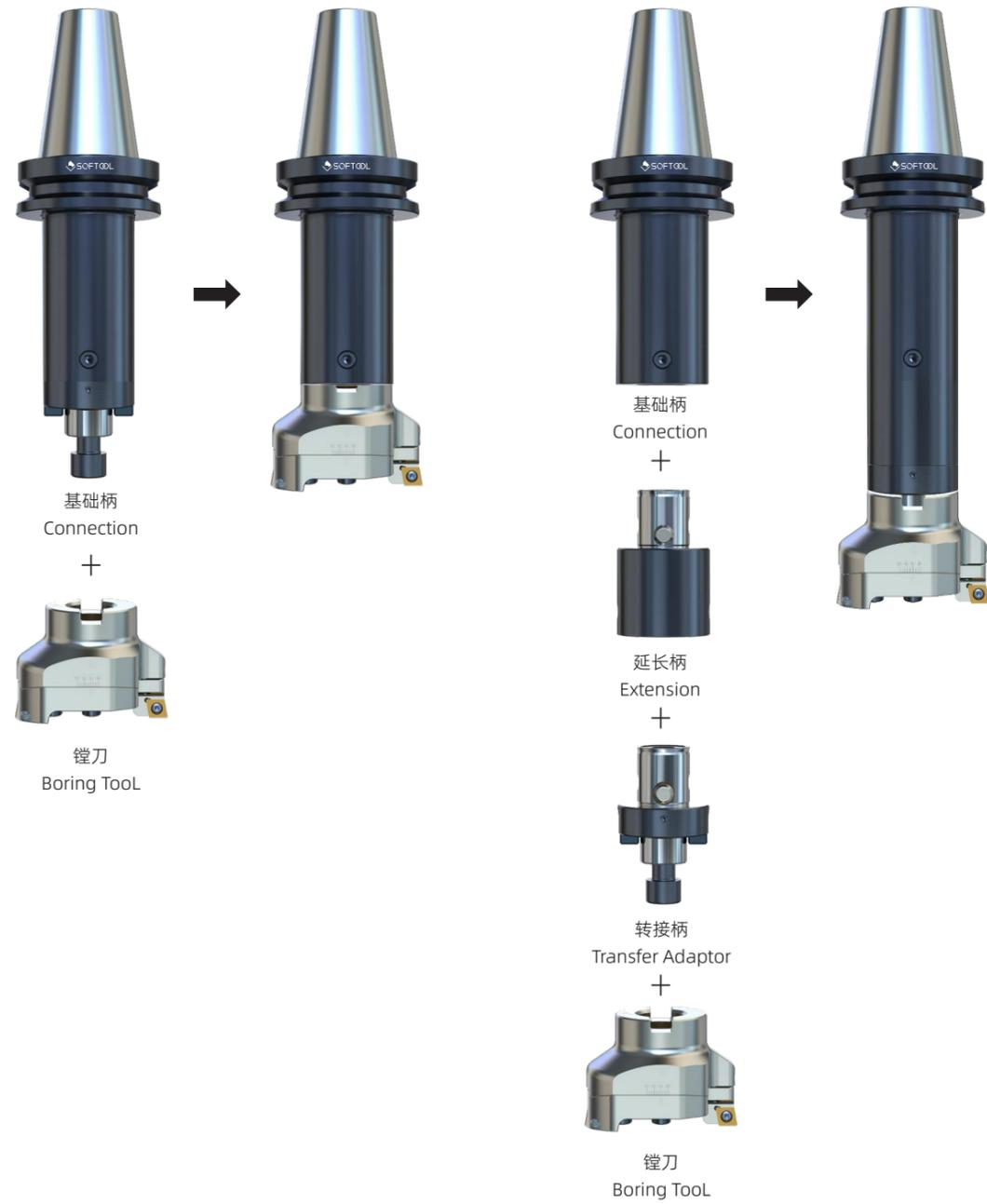



📍 中国 区	Nationwide	☎ +86 186 2267 5164
📍 东北 区	Northeast Area	☎ +86 133 3205 6691
📍 北 区	North Area	☎ +86 155 2213 5779
📍 南 区	South Area	☎ +86 139 2886 1339
📍 华东一区	East China Area I	☎ +86 189 0219 0578
📍 华东二区	East China Area II	☎ +86 189 6178 0014
📍 OEM&海外	OEM & Oversea Sales	☎ +86 131 1000 1570
📍 外贸销售	Export Sales	☎ +86 189 2008 0858



— 微信公众号 —

ADD: 天津市武清区京滨工业园京滨大道99号  
No. 99, Jingbin Avenue, Jingbin Industrial Park,  
Wuqing District, Tianjin, China

TEL: 022-60379917

E-mail: softool.sale@cxtc.com

WEB: www.xtc-softool.com